

THE UNITED REPUBLIC OF TANZANIA
NATIONAL EXAMINATIONS COUNCIL
CERTIFICATE OF SECONDARY EDUCATION EXAMINATION
NOVEMBER 1997

034

AGRICULTURAL SCIENCE
(For School Candidates only)

TIME: 2 ½ Hours.

INSTRUCTIONS

1. This paper consists of 35 questions in Sections A and B.
2. Answer ALL questions.
3. Read the instructions under each section carefully.
4. You are advised to spend 30 minutes on Section A and 120 minutes on Section B.
5. All answers must be written in the answer book provided.
6. Write your centre and index number on every page of your answer book.
7. All writing must be in blue/black ink or ball point pen.

maktaba.tetea.org



SECTION A

Nature of questions	=	multiple choice
Marks allocated	=	10 marks (10%)
Time allocated	=	30 minutes.

Answer all questions in this section. Under each question, only one of the four answers provided is the most correct. Write down the letter bearing the most correct answer in the answer book provided.

1. (i) The diagram below shows the size of mineral soil particle in mm (diameter).

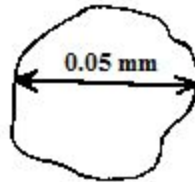

The soil particle in the diagram is

- A coarse sand
 - B gravel
 - C silt
 - D clay.
- (ii) If 50 kgN has to be applied per hectare in a rice field, how much sulphate of ammonia fertilizer containing 20% N should be applied on the farm?
- A 100kg
 - B 750kg
 - C 500kg
 - D 250kg
- (iii) The process of deposition of soil materials which have been removed from one soil horizon to another horizon is called
- A Illuviation
 - B Elluviation
 - C tobacco
 - D Alluviation
 - E Colluviation.
- (iv) The pH range 4.0 - 5.0 can be described as
- A moderately acidic
 - B strongly acidic
 - C very strongly acidic
 - D slightly acidic.

- (v) Rabbits eat grass. They are animals which can be classified in the category of
- A vegetarians
 - B ruminants
 - C non-ruminants
 - D none of the above
- (vi) Zinc in animal nutrition is used for:
- A formation of skin and hair
 - B maintenance of normal body growth
 - C metabolic processes in the body
 - D formation of enzymes.
- (vii) In livestock, outcrossing means mating
- A animals of the same breed
 - B animals of different breeds
 - C unrelated animals of the same breed
 - D unrelated animals of different breeds.
- (viii) Which of the following livestock diseases is NOT a bacterial disease?
- A Anthrax
 - B Tuberculosis
 - C Mastitis
 - D Coccidiosis.
- (ix) Which of the following diseases of tomatoes is a physiological disease?
- A Blossom end rot
 - B Early blight
 - C Late blight
 - D Damping off.
- (x) The most suitable sucker for planting bananas is called:
- A Water sucker
 - B Sword sucker
 - C Main sucker
 - D Follower sucker.

(xi)

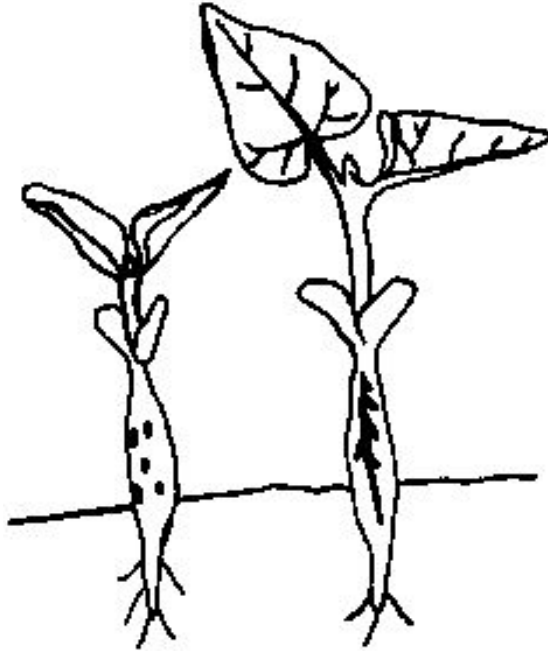

The pest responsible for the damage on young bean plants shown in the diagram above is:

- A Diopsis thoracica
- B Meloidogyne spp
- C Melanogromyza spp
- D Hover fly.

(xii)

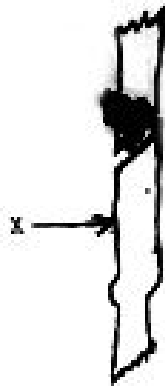

In plant propagation, the part labelled X in the diagram above is known as the

- A root stock
- B head stock
- C top graft
- D scion

- (xiii) The survey lines on the ground are aligned using
- A ranging poles
 - B surveyor's chain
 - C surveyor's level
 - D levelling staff.
- (xiv) Which part on a mouldboard plough assists in the complete burial of crop residues and trash?
- A The scraper
 - B The skin coulter
 - C The share
 - D The landside.

(xv)

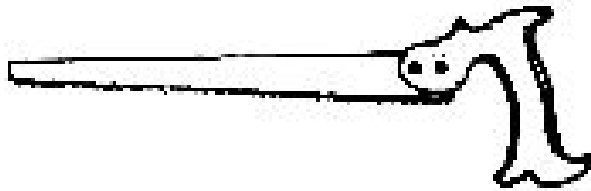

The saw shown in the diagram above is known as:

- A Coping saw
 - B Keyhole saw
 - C Compass saw
 - D Fretsaw.
- (xvi) In a four stroke cycle engine, when the engine completes the four strokes, the crank shaft and camshaft will have made
- A two and one complete revolutions respectively
 - B one and two complete revolutions respectively
 - C four and one complete revolutions respectively
 - D two and four complete revolutions respectively.
- (xvii) A middleman who travels from one place to another, buys goods from wholesalers and distributes/sells to retailers is known as
- A broker
 - B commission agent
 - C jobber
 - D prospective business man/woman.

(xiv)

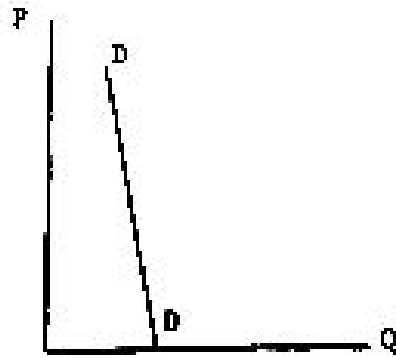

The demand curve DD in the diagram above shows

- A unitary demand
 - B elastic demand
 - C unit elastic demand
 - D inelastic demand.
- (xix) Beef and hides, cotton seed and cotton lint, sugar and molasses are good examples of which product-product relationship?
- A Joint products
 - B Competitive products
 - C Supplementary products
 - D Complimentary products.
- (xx) The direct benefits of forests are that they regulate
- A water and charcoal supplies
 - B climate and water supplies
 - C timber supplies and soil erosion
 - D pulp and soft wood supplies.

SECTION B

Nature of questions = short answer type
Marks allocated = 90 marks (90%)
Time allocated = 120 minutes.

Answer all questions. Credit will be given for answers which are precise, brief and to the point.

2.

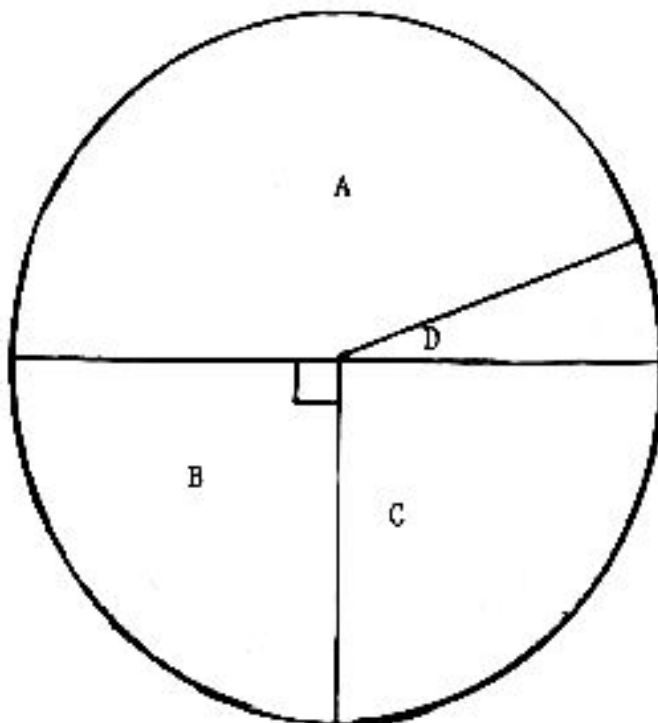

The diagram above represents an approximate composition of a top soil sample of a certain mineral soil.

- (a) Name the soil components labelled A, B, C and D.
 - (b) Outline three important roles of component D in the soil.
- 3.
- (a) Define the term “soil productivity”.
 - (b) Mr. Kwigema has a 10 ha farm on which he intends to grow wheat this year. Laboratory analysis of soil samples showed that in order to obtain high crop yields, he should apply 150kg N, 40 kg P_2O_5 and 20kg K_2O per hectare. How many 50kg bags of each of the following fertilizers should he apply to the whole area of his farm?
 - (i) Sulphate of ammonia - 21%N
 - (ii) Triple super phosphate (TSP) - 46% P_2O_5
 - (iii) Muriate of potash (MOP) - 60% K_2O

- 4.
- (a) Give the meaning of soil pH in words or by using formulae.
 - (b) The figure below represents a pH scale. Name the pH conditions at locations marked A, B and C on the pH scale.

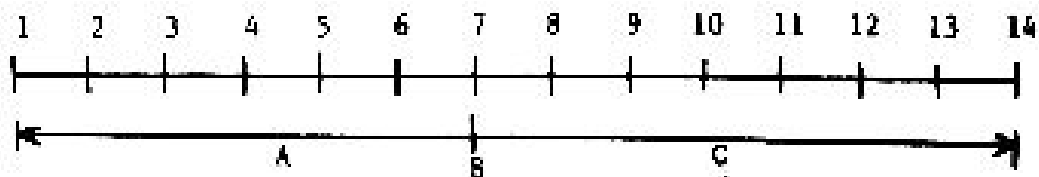

- (c) Name a material which you could add to a soil with pH 3.5 so as to raise its pH to 6.5
- (d) Outline two important beneficial effects of adding to the soil the material you have named in (c) above.

5. The diagram below represents a digestive system of some farm livestock.

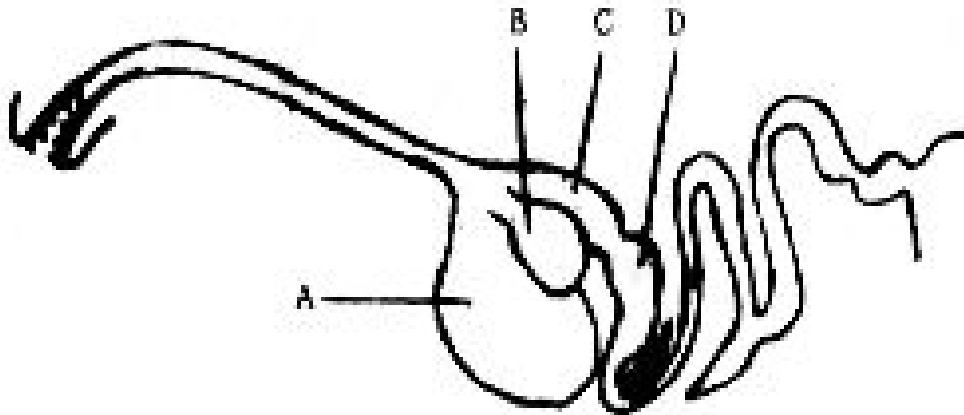

- (a) Name the type of digestive system.
 - (b) Name one type of farm livestock which possesses such a digestive system.
 - (c) Name the parts labelled A, B, C and D on the diagram.
 - (d) State the main digestive function of each of the parts labelled A and B.
6. Foot and mouth disease is a highly infectious disease of cattle in Tanzania.
- (a) What is the causal organism of the disease?
 - (b) Outline three outstanding symptoms of the disease.
 - (c) State two preventive measures of the disease.
- 7.
- (a) Define the term “vices” as it is used in poultry production.
 - (b) Enumerate four vices which can occur in chicken kept in a deep litter house.
 - (c) Outline five poultry husbandry practices for controlling vices in a flock of poultry birds kept in a deep litter house.
8. Imagine that you have completed school and you are engaged in farming business with your parents at home. Describe briefly how you could raise a crop of cassava under the following headings:
- (a) Soil requirements
 - (b) Land preparation
 - (c) Planting
 - (d) Weeding
 - (e) Harvesting.
9. (a) Although weeds are known to affect crop production seriously but they are also beneficial in some ways. State two outstanding benefits of weeds.
- (b) In the middle column of the table below are listed two types of weeds by their scientific names. Complete the table by filling in columns one and three.

Common name	Scientific name	Life span
(i) _____	<u>Cynodon dactylon</u>	_____
(ii) _____	<u>Striga spp</u>	_____

10. (a) Wood preservatives may be grouped into three types. Name any two types of wood preservatives.
(b) Explain briefly two advantages and two disadvantages of any one type of wood preservatives among those you have mentioned in (a) above.
11. The various types of insecticides which are used for controlling crop pests are obtainable on the market in various formulations.
(a) Enumerate four common formulations of insecticides.
(b) Outline six important rules which must be observed before and when applying insecticides on a growing crop.
12. The two diagrams A and B below represent two different types of farm machinery cooling systems.

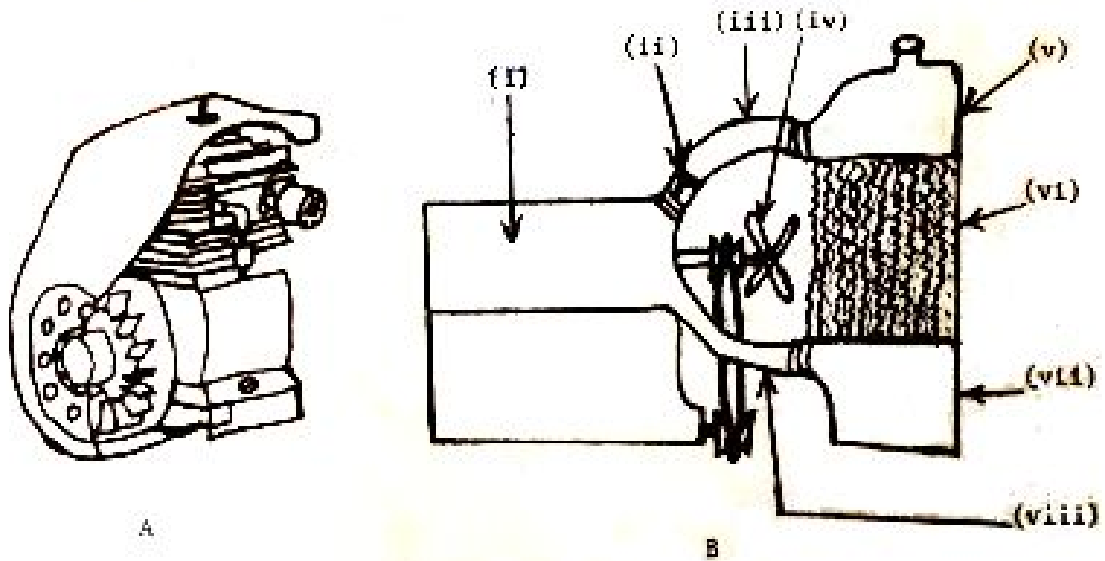

- (a) Name each of the cooling systems.
(b) Name the parts labelled (i) to (viii) on diagram B.

13. The diagrams A, B, C, D, E and F represent farm workshop tools.

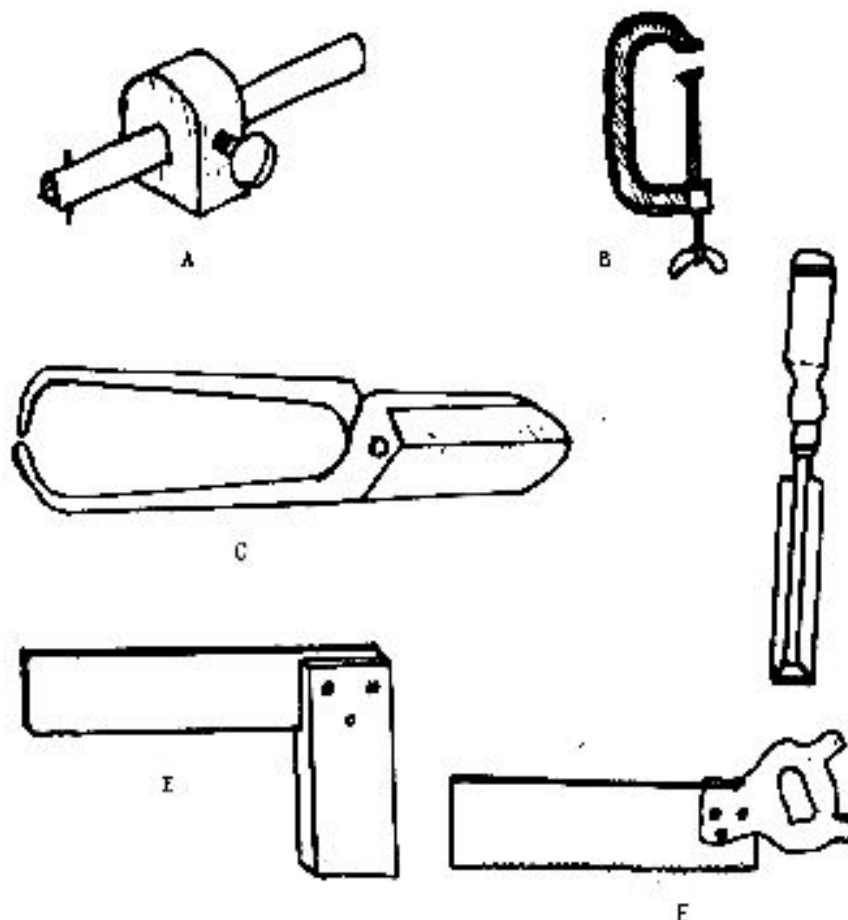

- (a) Name each type of working tool.
(b) State one main use for each type of tool.
14. State briefly the use of each of the following surveying instruments:
- (a) Tripod level
(b) Compass
(c) Odometer
(d) Chain
(e) Levelling staff
(f) Ranging poles.
15. (a) What do you understand by each of the following as they are used in agricultural economics?
- (i) Market price
(ii) Price at factor cost
(iii) Shadow price.

- (b) Farmers in Tanzania are faced with a problem of unstable prices for their produce.
 - (i) Briefly outline any three causes of such price instability.
 - (ii) Outline any four ways by which the government and other institutions may use to regulate price fluctuations of agricultural products.

 - 16. (a) Outline three methods that can be used to calculate the depreciation of farm assets.
 - (b) List three causes of depreciation of farm assets.
 - (c) Mr. Onyango has bought a tractor for T.Shs.9,000,000/= which he expects to last for 15 years before writing it off when its value will be T.Shs.900,000/=. Use the straight line method to calculate the annual depreciation of the tractor.
-