

THE UNITED REPUBLIC OF TANZANIA
NATIONAL EXAMINATION COUNCIL OF TANZANIA
FORM TWO NATIONAL ASSESSMENT

091

ENGINEERING DRAWING

Time: 2:30 Hours.

SOLUTIONS

Year: 2021

Instructions

1. This paper consists of sections **A** and **B** with a total of **seven (7)** questions.
2. Answer **all** questions.
3. Section A carries **15** marks; section B carries **70** marks and section C carries **15** marks.
4. All writing must be in **black** or **blue** ink and drawings must be in **pencil**.
5. Cellular phones and unauthorized materials are **not allowed** in the examination room.
6. Write your **Assessment Number** at the top-right hand corner of every page.

FOR EXAMINER'S USE ONLY		
QUESTION NUMBER	SCORE	EXAMINER'S INITIALS
1		
2		
3		
4		
5		
6		
7		
8		
9		
10		
TOTAL		
CHECKER'S INITIALS		



1. A certain industry that deals with pavement blocks needs a metal pavement block pattern. The shapes of that pattern are pentagon, heptagon, and octagon, and the size of one side is 20 mm. Construct these polygons into one drawing showing all the construction lines.

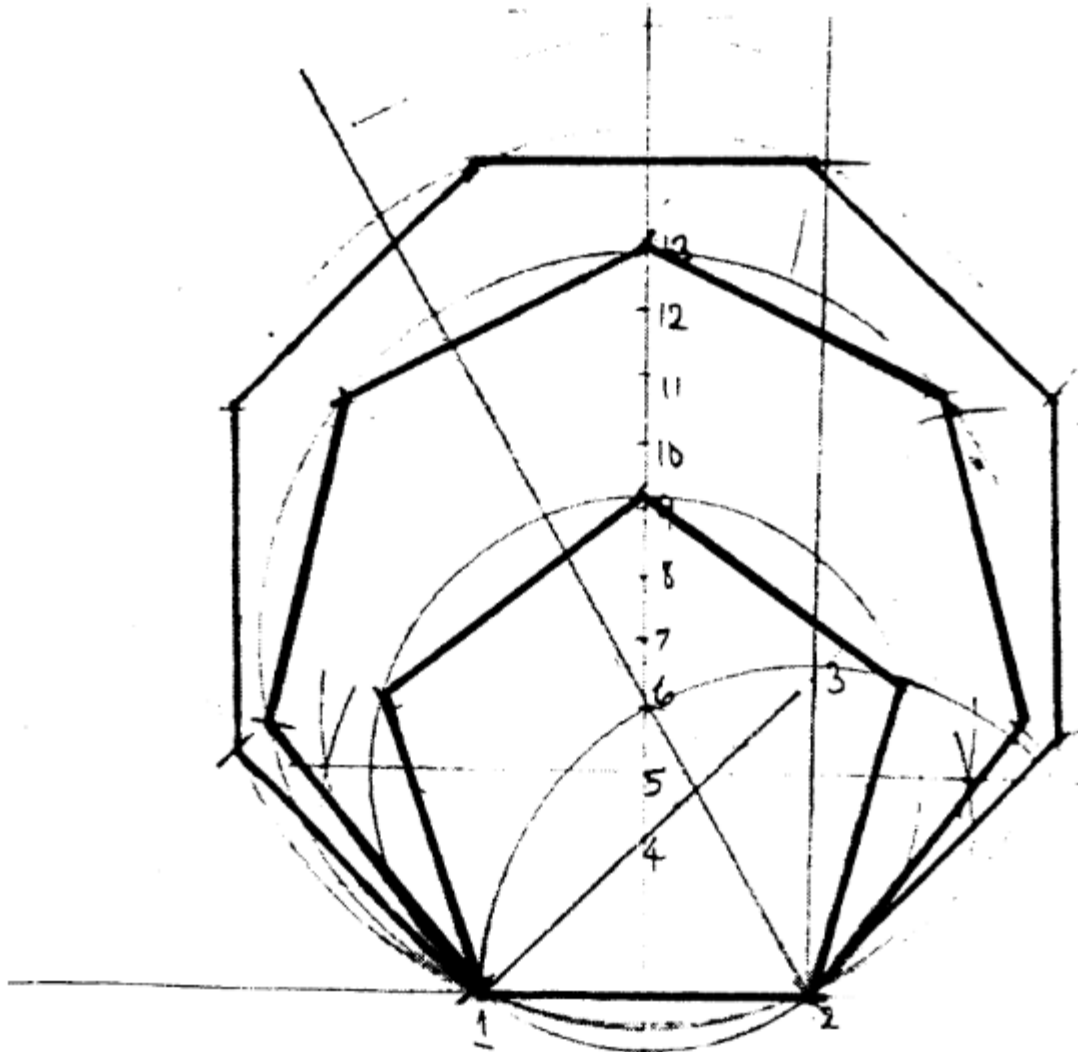

2. Figure 1 shows two cylinders of unequal diameters which are supposed to be welded at right angle (90°). Construct a line of intersection to lead the welding process.

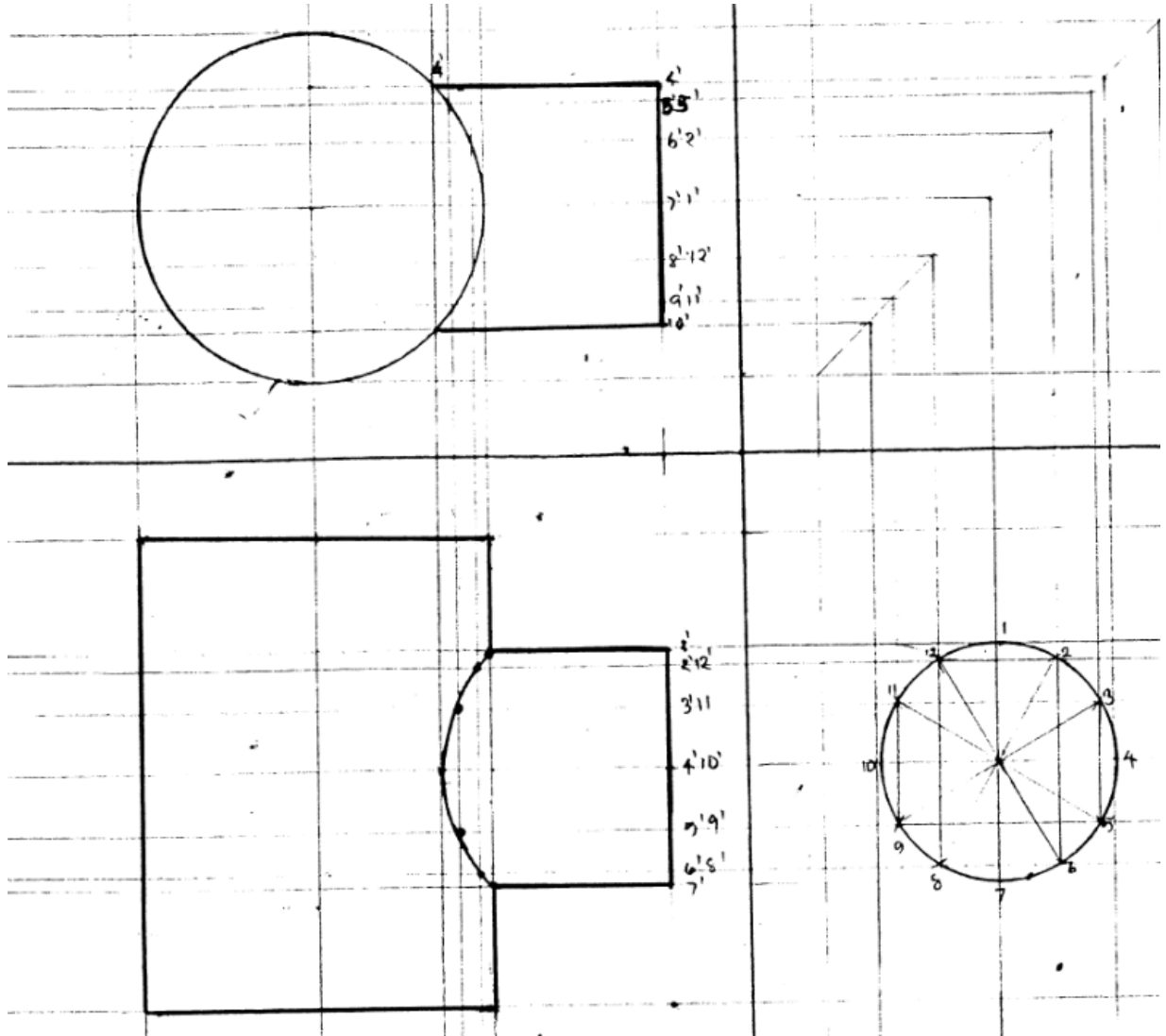

3. Two plates having a thickness size of 12 mm are bolted and held together by using a bolt of the size M12. By applying freehand sketch techniques, show how the two plates are bolted together.

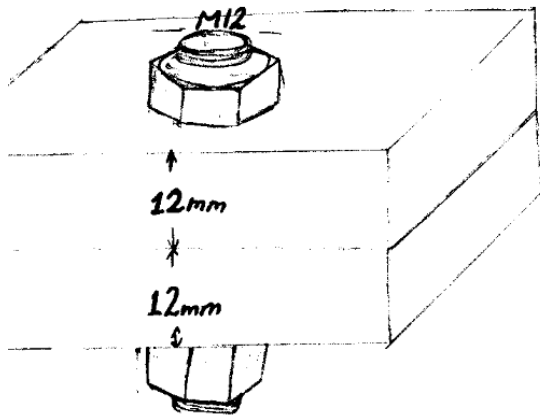

OR

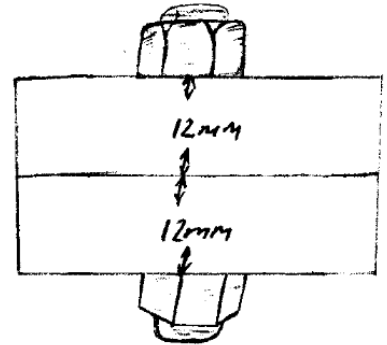

4. A school workshop teacher wants to manufacture a machine component which is similar to the drawing shown in Figure 2. For easier understanding of the diagram, he wishes to change the view in oblique projection and asked you for your assistance. Convert the component in oblique projection as he wishes.

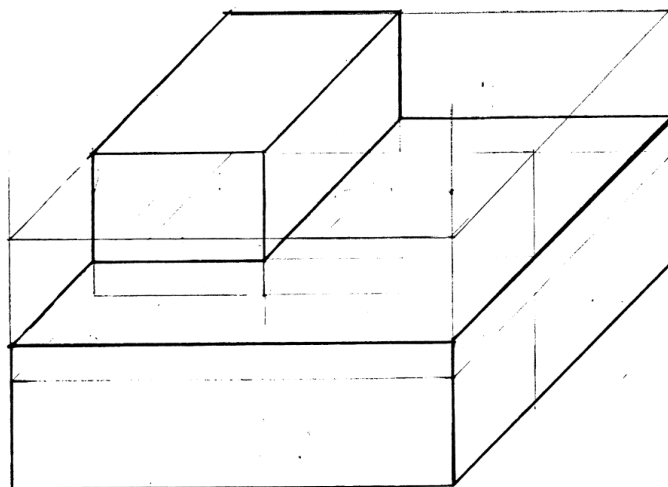

5. John's father had a piece of land shaped like Figure 3. He didn't know the size of the land because of the shape. Change the shape to a square in order for him to be able to measure the land. Consider that all dimensions are in mm.

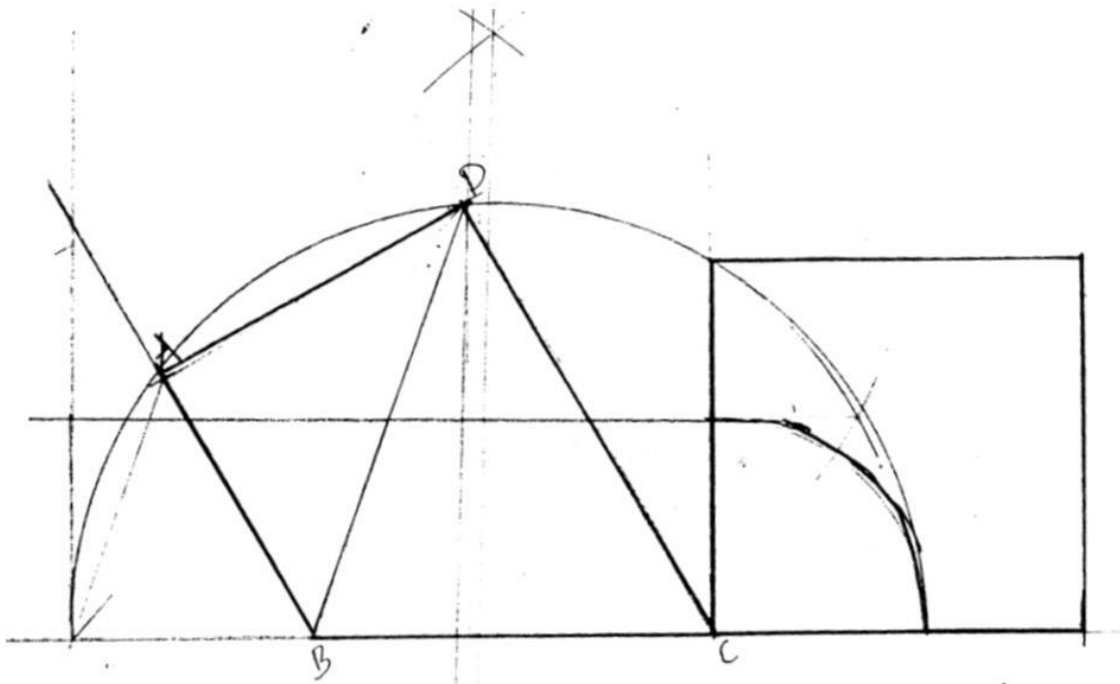

6. Figure 4 shows the elevation of a catch plate. Redraw the given elevations showing clearly the constructions lines used to determine the centres of the various circular arcs.

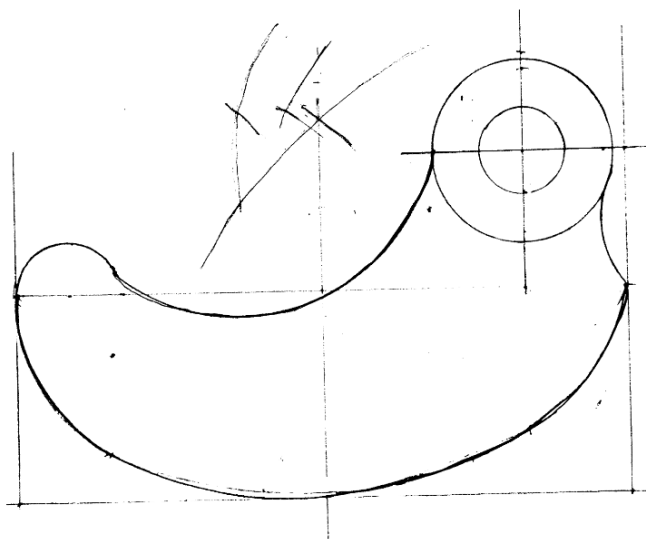

7. Figure 5 shows the machine jaw drawn in oblique projection. Redraw in isometric projection.

