

**THE UNITED REPUBLIC OF TANZANIA  
NATIONAL EXAMINATION COUNCIL OF TANZANIA  
FORM TWO NATIONAL ASSESSMENT**

**091**

**ENGINEERING DRAWING**

**Time: 2:30 Hours.**

**SOLUTIONS**

**Year: 2023**

---

**Instructions**

1. This paper consists of sections **A** and **B** with a total of **seven (7)** questions.
2. Answer **all** questions.
3. Section A carries **15** marks; section B carries **70** marks and section C carries **15** marks.
4. All writing must be in **black** or **blue** ink and drawings must be in **pencil**.
5. Cellular phones and unauthorized materials are **not allowed** in the examination room.
6. Write your **Assessment Number** at the top-right hand corner of every page.

<b>FOR EXAMINER'S USE ONLY</b>		
<b>QUESTION NUMBER</b>	<b>SCORE</b>	<b>EXAMINER'S INITIALS</b>
1		
2		
3		
4		
5		
6		
7		
8		
9		
10		
<b>TOTAL</b>		
<b>CHECKER'S INITIALS</b>		



1. (a) Form two students were assigned to drill 13 holes on the 14 m bar in equal space, but the last hole should be at 12.4m from the margin. Using a scale of 1cm=1cm, prepare the marked scale bar to indicate the point required to be drilled.

(b) The figure below shows quadrilateral MPQN drawn in the angle of 30° with point M. By using radial lines method and point Z as the focal point; deduce the figure in the ratio of 5/3.

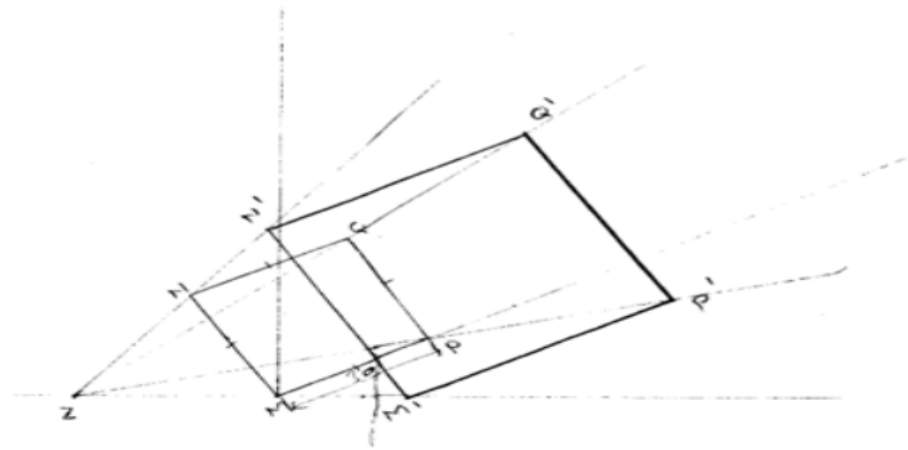
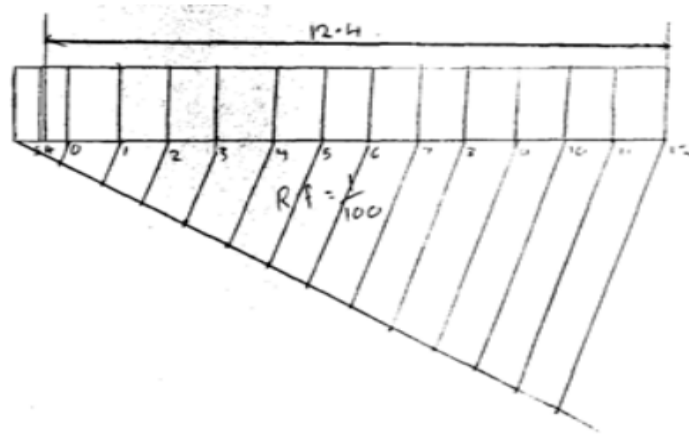

2. The figure below shows a hard plastic engine mounting require by a Car Company. By using full size scale and isometric projection; construct a free hand sketch of a part.

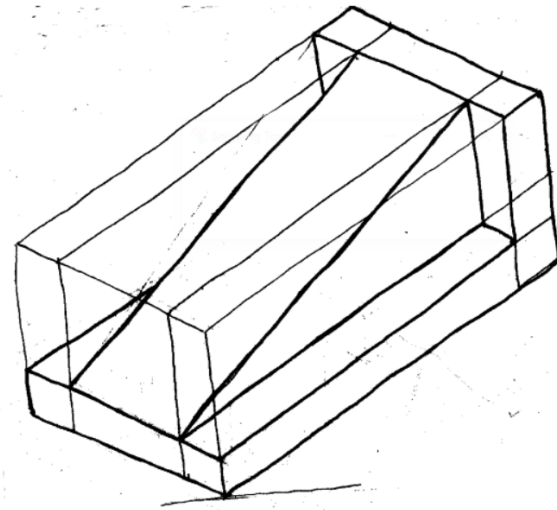

3. (a) Wit the help of a ruler and compass; construct the following angle:
- (i)  $30^\circ$
  - (ii)  $45^\circ$

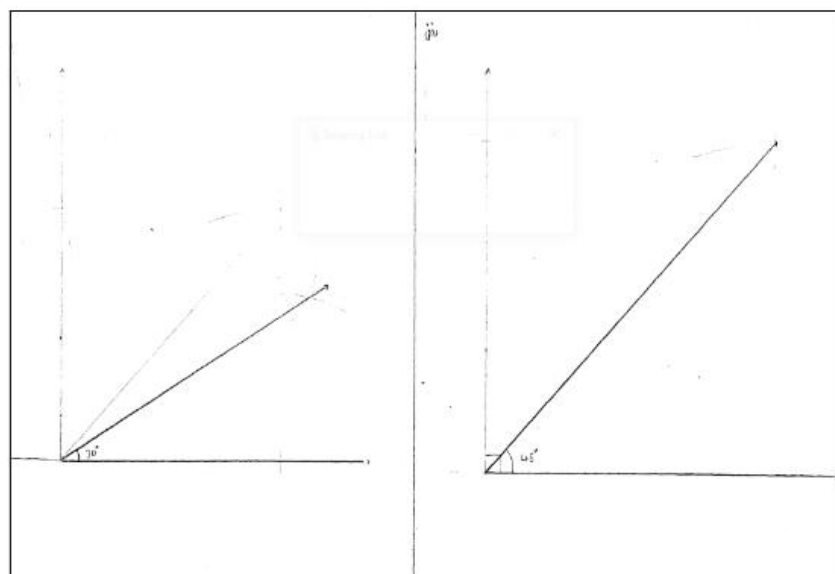

(b) Draw a circle with diameter of 80 mm and show the following parts:

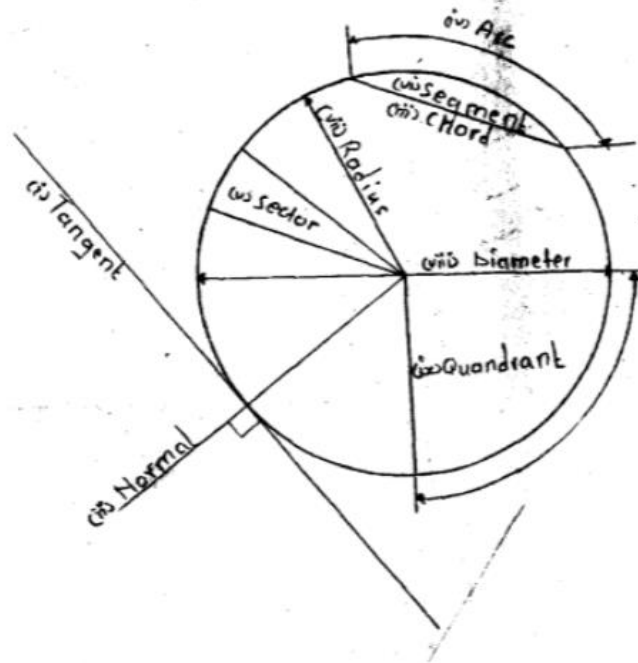

(c) (i) Tangent (ii) Normal (iii) Chord (iv) Arc (v) Sector (vi) Segment (vii) Radius (viii) Diameter (ix) Quadrant.

4. (a) A motor vehicle chassis was required to be welded with various welding technique at a Metal Welding Company. Illustrate how you would do the following welding techniques: (i) Fillet weld (ii) V-Butt weld (iii) Butt weld (iv) Sport weld.

(b) Figure (i)-(iii) show mechanical parts drawn with incorrect rules of dimensioning. Re-draw the figures with the correct methods of dimensioning in the standard paper provided.

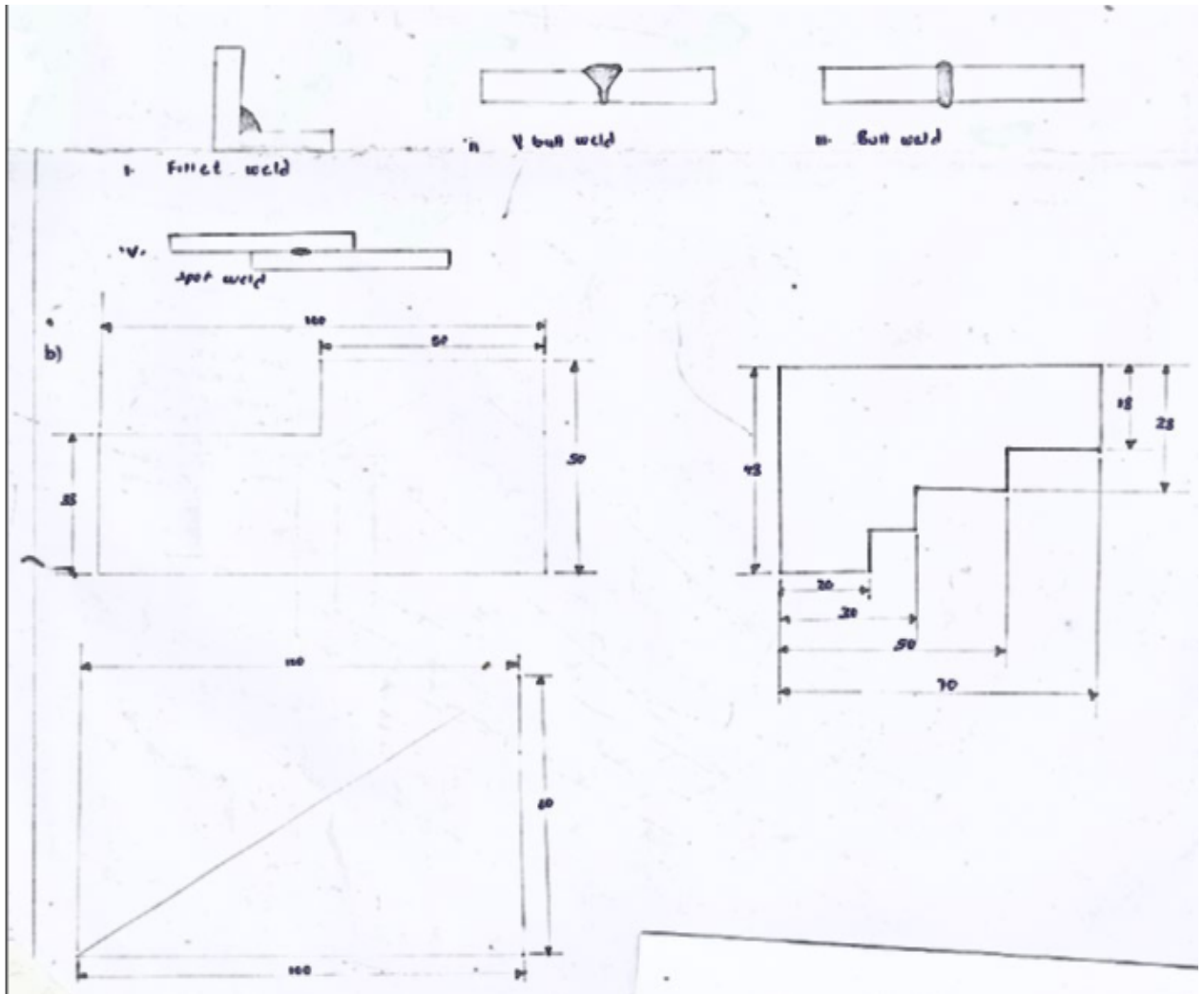

5. (a) Using free hand method and isometric projection, construct the mechanical tool shown in the figure.

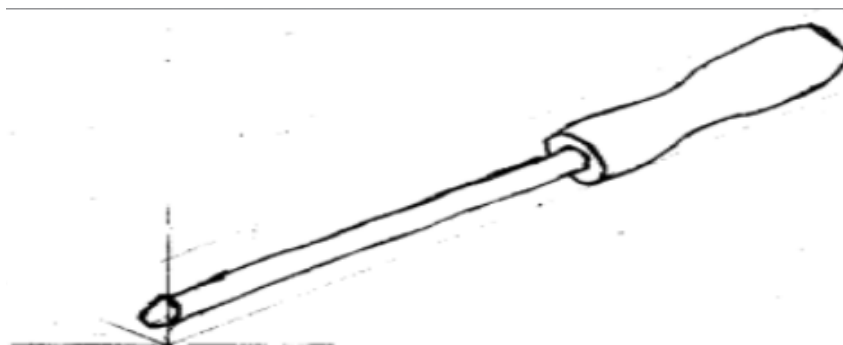

(b) A football coach needs several squares plastic pyramids to be used in his coaching activities. Design a required pyramids to be manufactured in oblique projection. The altitude of pyramids is 80 mm and its sides is 40 mm.

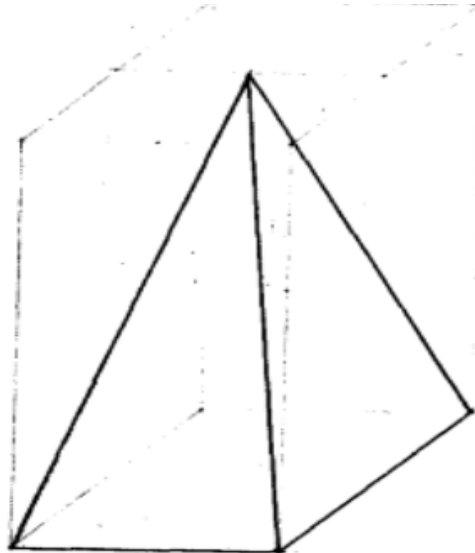

6. The figure below is a pictorial view of casted block; draw in full scale size the isometric projection of a block. All construction lines should be clearly shown.

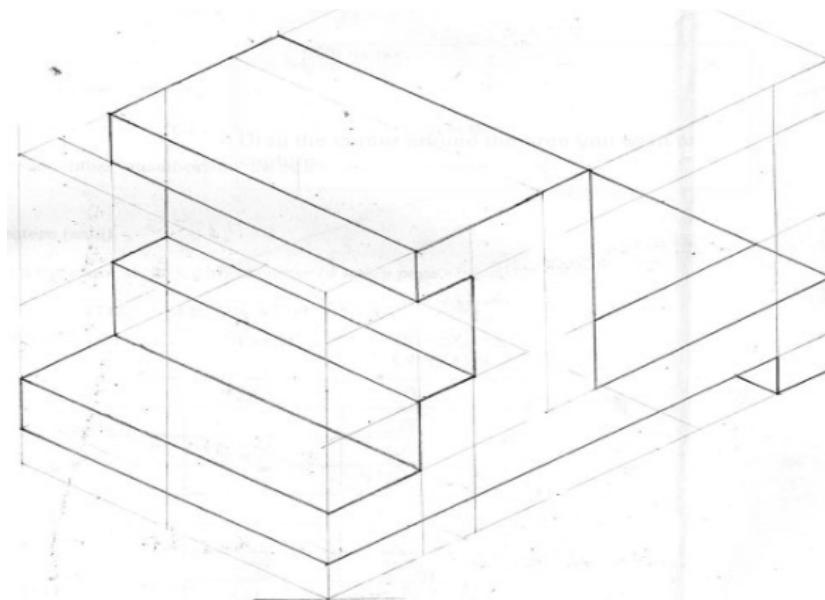

7. The figure below shows the stopper drawn in isometric projection. Draw the stopper in full size dimensions using principles and rules of dimensioning. The dimensions of the object are as follows:

