

**THE UNITED REPUBLIC OF TANZANIA**  
**NATIONAL EXAMINATIONS COUNCIL OF TANZANIA**  
**FORM TWO NATIONAL ASSESSMENT**

**035**

**ENGINEERING SCIENCE**

**Time: 2:30 Hours**

**Year: 2021**

**Instructions**

1. This paper consists of sections **A**, **B** and **C** with a total of **ten (10)** questions.
2. Answer **all** questions.
3. Section **A** and **C** carry **fifteen (15)** marks each, section **B** carries **seventy (70)** marks.
4. Cellular phones and any unauthorized materials are **not** allowed in the assessment room.
5. Write your **Assessment Number** at the top right hand corner of every page.

<b>FOR ASSESSOR'S USE ONLY</b>		
<b>QUESTION NUMBER</b>	<b>SCORE</b>	<b>ASSESSOR'S INITIALS</b>
1		
2		
3		
4		
5		
6		
7		
8		
9		
10		
<b>TOTAL</b>		
<b>CHECKER'S INITIALS</b>		



## SECTION A (15 MARKS)

Answer **all** questions in this section

1. Choose the correct answer from the given alternatives and write its letter in the box provided.

i) All measurements in engineering science are related to the fundamental quantities. What are the five fundamental physical quantities in the SI unit system?

A. Mass, Temperature, Light, Time and Length.

B. Time, Length, Mass, Temperature, and Luminous Intensity.

C. Length, Density, Temperature, Mass and Time.

D. Luminous Intensity, Light, Length, Mass and Temperature.

ii) An operator man uses a hydraulic press to lift a container. What will be the mechanical advantage, if the hydraulic press is frictionless?

A. Greater than velocity ratio

B. Small than velocity ratio

C. Equal to velocity ratio

D. Twice than velocity ratio.

iii) Form Two students were arguing about examples of the effects of force which can be experienced on a body. Which is true concerning the effects of forces experienced on body?

(i) A force reduces the speed of a body in motion.

(ii) A force can cause a body to move faster.

(iii) Shape can be changed to a new shape by a force.

(iv) The direction of a moving body can be changed to other direction by force.

(v) Mass of a body is increased by force.

(vi) A force can cause damage such as a crack on body.

- A. (i), (ii), (iii), (iv) and (vi)
- B. (i), (ii), (iii), (iv) and (v)
- C. (i), (ii), (iii), (v) and (vi)
- D. (i), (ii), (iii), (v) and (iv)

iv) An engineer observed that, parts of machine rubbing against each other causes friction that leads to unnecessary heat, noise and wear. How can this problem be minimised?

- A. By reducing the speed of the rubbing surface in contact
- B. By increasing the areas of the rubbing surface in contact
- C. By replacing the parts of rubbing surfaces with parts made of graphite material.
- D. By lubricating the rubbing surfaces in contact with grease and oil.

v) You are assigned to make a presentation in the class on how to make a sensitive or quick to act thermometer. What features will you consider when manufacturing the thermometer?

- A. A large bulb with a wide capillary tube
- B. Wide capillary in small bulb
- C. Large bulb with a narrow capillary tube
- D. Small bulb with a thin glass wall

vi) An electric bell is placed in a vacuum room and starts ringing when switched on. What will be witnessed by an observer outside the room?

- A. The observer will not hear the sound.
- B. The observer will hear the echo of the sound.
- C. The observer will hear loud sound.
- D. The observer will hear some sort of reverberation.

vii) Form two student was assigned to measure the potential difference between the points and an electric current in a circuit. Which measuring instruments

should the student have before carrying out the measurements?

- A. A wattmeter and an Ammeter
- B. A voltmeter and Wattmeter
- C. Voltammeter and an Ammeter
- D. A voltmeter and an Ammeter.

viii) Kazimoto who is a Form Two student was pushing his books cabinet to its position after finishing the cleaninnes of his room. During this activity his friends Maganga, Gwalu, and Hogoma, who were watching him made a coment?

- (i) Maganga said: Good Kazimoto, you are so powerful as you have managed to use your energy with respect to time and power with energy to store the cabinet to its position.
- (ii) Gwalu commented to Maganga: Power and energy are two different things, energy is the Power per time taken and power is the ability to do work.
- (iii) Hogoma responded to Gwalu: Power is the rate of doing work and energy is the ability to do work.
- (iv) Kazimoto commented as well that, energy is the capacity to perform work while power is the energy consumed per time taken.

From their arguments, who was right?

- A. Kazimoto and Gwalu
- B. Kazimoto and Hogoma
- C. Gwalu and Hogoma
- D. Maganga and Kazimoto.

ix) One student was assigned by a teacher to write a formula for calculating resultant force (R) formed by two forces, pulling a heavy concrete slab along a horizontal surface by means of two ropes where the ropes made an angle of

90° between them. If the forces in the ropes were  $F_1$  and  $F_2$  respectively which is the correct formula?

A.  $R = \sqrt{F_1^2 + F_2^2}$

B.  $R = \sqrt{F_1^2 - F_2^2}$

C.  $R = \sqrt{F_1 + F_2}$

D.  $R = \sqrt{F_1 - F_2}$



x) Engineering Science teacher presented the diagram shown in Figure 1 on the blackboard and asked the students to give the name of the product of the parameters 'F' and 'a' what will be the student answer to the teacher?

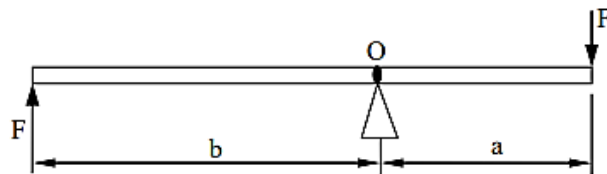

A. Workdone.

B. Torque.

C. Moment.

D. Impulse.

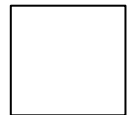

2. Match the linear motion actions in List A with the corresponding parameters in List B by writing the letter of the correct answer in the table provided.

LIST A	LIST B
i) Is a decreasing velocity with time	A. Acceleration
ii) It is a distance in a specific direction	B. Change in velocity
iii) Is a path of an object from one point to another	C. Displacement
iv) Is a rate of change of displacement	D. Distance
v) Is a rate of change of velocity	E. Gravitational acceleration
	F. Retardation
	G. Speed
	H. Velocity

**ANSWERS:**

List A	(i)	(ii)	(iii)	(iv)	(v)
List B					

### SECTION B (70 MARKS)

Answer **all** questions from this section

3. Given the data in the table below:

Test	Distance in meters	Time taken in seconds
1	30	10
2	42	12

a) Calculate the initial velocity and uniform acceleration

.....  
.....  
.....  
.....  
.....  
.....

b) Determine the final velocity at each round of a test. The recorded data provided were as shown.

.....  
.....  
.....  
.....  
.....

4. (a) Draw a leclanche cell diagram showing the structure of the cell, and name its four main components.

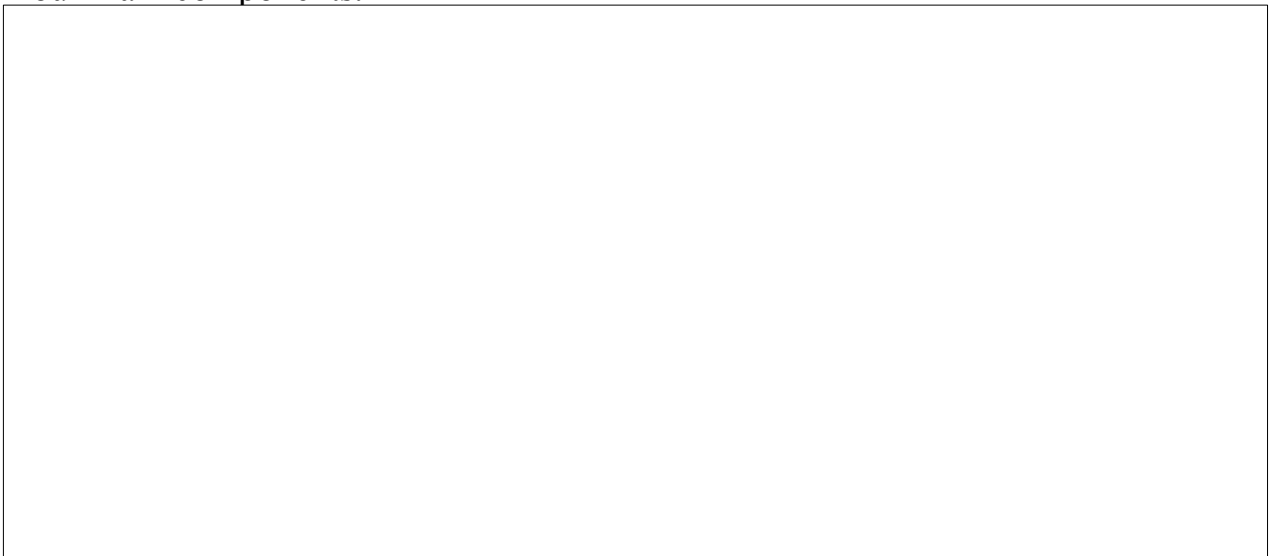

(b) (i) Briefly explain the effect of the formation of a layer of hydrogen on the positive terminal.

.....  
.....  
.....  
.....  
.....  
.....  
.....  
.....

(ii) How can the formation of a layer of hydrogen on the positive terminal in (b)(i) prevented.

.....  
.....  
..  
.....  
.....  
.....  
.....

(c) Give one advantage and one disadvantage of using the cell

.....  
.....  
.....  
.....  
.....  
.....



5. (a) A form Two teacher wrote the following statement on the blackboard “friction force is directly proportional to the normal reaction between two surfaces in contact with relative motion” Derive a mathematical equation represented by this statement.

.....

.....

.....

.....

.....

.....

.....

.....

.....

.....

.....

.....

.....

.....

.....

.....

.....

.....

.....

.....

.....

.....

(b) Using the formula obtained in (a), find the coefficient of friction where a block of 2kg is pulled on a rough horizontal surface with a force of 15N.

.....

.....

.....

.....

.....

.....

.....

.....

.....

.....

.....

.....  
.....  
.....

6. In an experiment of expansion of metals, student heated a steel ball to a temperature of  $50\text{ }^{\circ}\text{C}$  to give a diameter of  $50.25\text{ mm}$ . The ball was then placed over a hole of diameter  $50\text{ mm}$ . Estimate the temperature of the ball as a result of dropping it through the hole. (Consider  $\alpha = 0.000012/^{\circ}\text{C}$ ).

.....  
.....  
.....  
.....  
.....  
.....  
.....  
.....  
.....  
.....  
.....  
.....  
.....  
.....  
.....  
.....  
.....  
.....  
.....  
.....  
.....  
.....

7. Suppose you are given a 100 g of lead shots, measuring cylinder partly full of water to a reading of 80ml. When lead shots placed into it, the reading rose to 88.8ml. Estimate the density and relative density of the lead shots.

.....

.....

.....

.....

.....

.....

.....

.....

.....

.....

.....

.....

.....

.....

.....

.....

8. (a) In an engineering science laboratory teacher received the the following equipment: Wheelbarrow, Scissors, Spade, Nut Cracker, Tong and Fishing rod. Arrange these equipments according to their classes of lever.

.....

.....

.....

.....

.....

.....

.....

.....

.....

.....

.....

.....

.....

.....

.....

.....

(b) A student used a lever to shift a heavy iron block from one point to another during the cleanliness session in the workshop as shown in the Figure 2. Calculate the mechanical advantages of this lever.

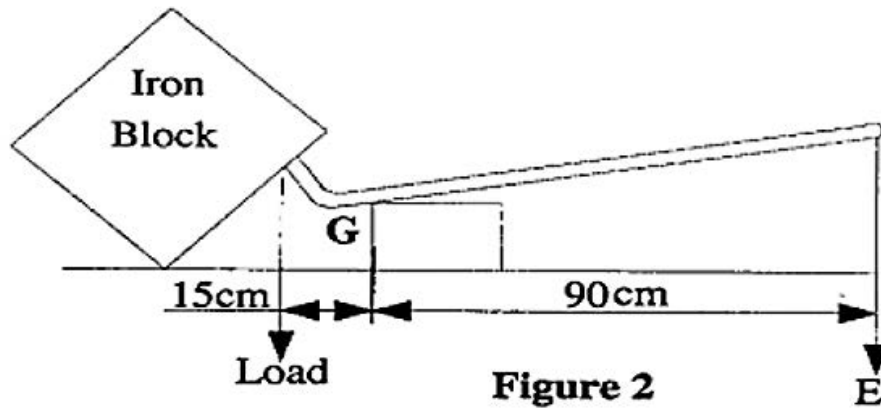

.....

.....

.....

.....

.....

.....

.....

.....

.....

.....

.....

.....

9. (a) A motor vehicle technician was servicing an engine in an automotive garage. He noted that the engine has mass of 150 kg and suspended by a crane with 4m above the ground. Determine the potential energy due to its position.

.....

.....

.....

.....

.....

.....

.....

.....

.....

.....

.....

.....

.....

.....

.....

.....

.....

.....

.....

.....

.....

.....

.....

(b) If the engine in (a) falls to the ground from that height; Calculate the velocity and kinetic energy of the engine at the point of impact with the ground.

.....

.....

.....

.....

.....

.....

.....

.....

.....

.....

.....

.....

.....

.....

.....

.....

.....

.....

.....

.....

.....

.....

.....

(c) Determine the kinetic energy and the potential energy of the engine after falling 3m. Neglect air resistance.

.....

.....

.....

.....

.....

.....

.....

.....

.....

.....

.....

### SECTION C (15 Marks)

Answer all questions

10. A form two student prepared an experiment in laboratory to determine the resistance 'R' of a metallic conductor. She closed the switch K, and adjusted the rheostat 'R<sub>n</sub>' to different positions to increase the current. For each position she recorded the readings 'V' and 'I' of the voltmeter and ammeter respectively.

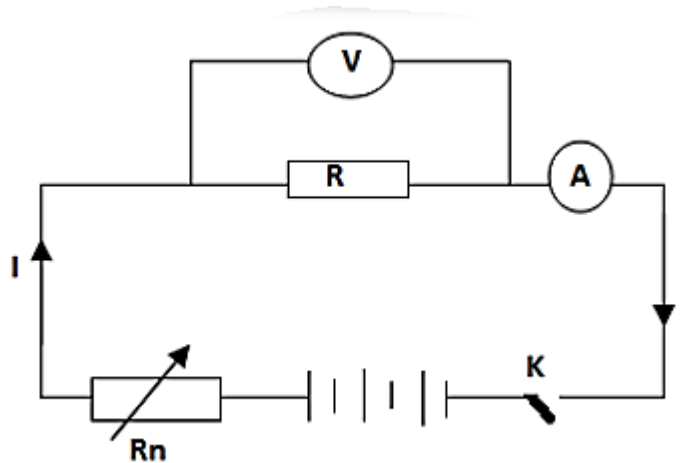

Table 2:

I(amps)	1	2	3	4	5	6
V(Volts)	2	4	6	8	10	12
$\frac{V}{I}$						

From the Table 2 answer the following questions.

- Find the ratio  $\frac{V}{I}$  for each pair and fill the Table 2.
- Plot the graph of V against I
- Calculate the gradient 'S' of the graph drawn in (b)
- Compare the value of the gradient 'S' obtained in (c) and the values of the

ratio  $\frac{V}{I}$  obtained in (a).

e) State the relation between S and  $\frac{V}{I}$

f) Which physical quantity is represented by the gradient 'S'?

g) Determine the value of the resistance 'R' of the metallic conductor.

.....

.....

.....

.....

.....

.....

.....

.....

.....

.....

.....

.....

.....

.....

.....

.....

.....

.....

.....

.....

.....

.....

.....



A series of horizontal dotted lines for writing.