

Complete revision for
**Secondary Basic Applied
Mathematics**

BAM

With 300+
Questions with Answers

Loibanguti, B.M

BSc. with Education - University of Dar Es Salaam, Tanzania
for more visit www.jihudumie.com

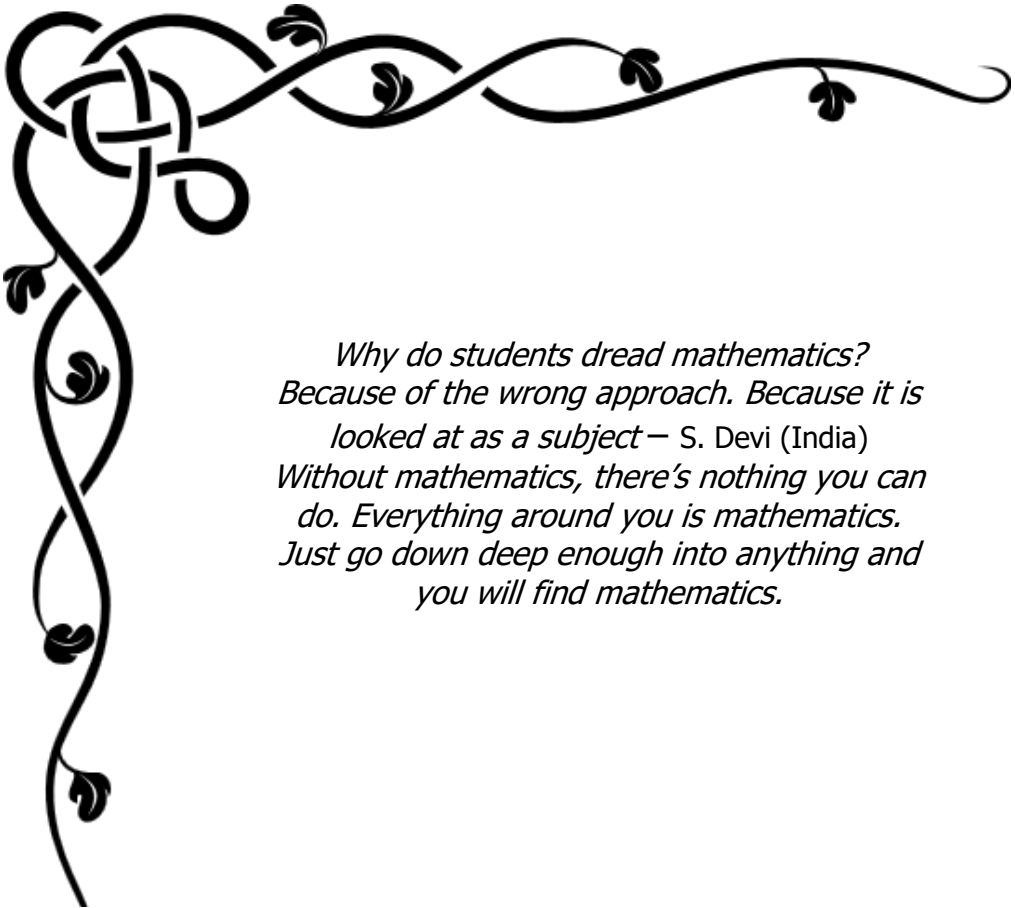

*Why do students dread mathematics?
Because of the wrong approach. Because it is
looked at as a subject – S. Devi (India)
Without mathematics, there's nothing you can
do. Everything around you is mathematics.
Just go down deep enough into anything and
you will find mathematics.*



DEDICATED TO

1. The Lord Jesus Christ.
2. Galileo Galilei 1564–1642
3. Muhammad ibn Musa al-Khwarizmi the father of Algebra



Text © Loibanguti, B 2022
Author: Baraka Loibanguti
Editor: Baraka Loibanguti
Publisher: Baraka Loibanguti
Cover Design: Baraka Loibanguti

Physical Address;
Baraka Loibanguti,
P.O Box 687,
Songea Town,
Ruvuma Tanzania.

Or

Baraka Loibanguti,
P.O Box 7462,
Arusha,
Tanzania.

E-Mail: barakaloibanguti@gmail.com | info@jihudumie.com
Website: www.jihudumie.com
Tel: +255 621842525 | +254 735 748 429
Office Tel: +255 744 078 287 (Working Hours Only)



Left blank on purpose



Table of contents

EXAMINATION ONE	8
EXAMINATION TWO	10
EXAMINATION THREE	13
EXAMINATION FOUR	16
EXAMINATION FIVE	19
EXAMINATION SIX	21
EXAMINATION SEVEN	24
EXAMINATION EIGHT	26
EXAMINATION NINE	30
EXAMINATION TEN	33
EXAMINATION ELEVEN	35
EXAMINATION TWELVE	37
EXAMINATION THIRTEEN	40
EXAMINATION FOURTEEN	43
EXAMINATION FIFTEEN	45
EXAMINATION SIXTEEN	47
EXAMINATION SEVENTEEN	49
EXAMINATION EIGHTEEN	51
EXAMINATION NINETEEN	54
EXAMINATION TWENTY	56
EXAMINATION TWENTY-ONE	59
EXAMINATION TWENTY-TWO	61
EXAMINATION TWENTY-THREE	64
EXAMINATION TWENTY-FOUR	67
EXAMINATION TWENTY-FIVE	70
EXAMINATION TWENTY-SIX	73
EXAMINATION TWENTY-SEVEN	76
EXAMINATION TWENTY-EIGHT	79
EXAMINATION TWENTY-NINE	82
EXAMINATION THIRTY	85
EXAMINATION THIRTY-ONE	Error! Bookmark not defined.
ANSWERS	
EXAMINATION ONE	91



EXAMINATION TWO	92
EXAMINATION THREE	93
EXAMINATION FOUR	95
EXAMINATION FIVE	96
EXAMINATION SIX	97
EXAMINATION SEVEN	98
EXAMINATION EIGHT	98
EXAMINATION NINE	99
EXAMINATION TEN	100
EXAMINATION ELEVEN	101
EXAMINATION TWELVE	103
EXAMINATION THIRTEEN	104
EXAMINATION FOURTEEN	105
EXAMINATION FIFTEEN	106
EXAMINATION SIXTEEN	107
EXAMINATION SEVENTEEN	108
EXAMINATION EIGHTEEN	109
EXAMINATION NINETEEN	110
EXAMINATION TWENTY	111
EXAMINATION TWENTY-ONE	113
EXAMINATION TWENTY-TWO	114
EXAMINATION TWENTY - THREE	115
EXAMINATION TWENTY - FOUR	116
EXAMINATION TWENTY - FIVE	117
EXAMINATION TWENTY - SIX	118
EXAMINATION TWENTY-SEVEN	120
EXAMINATION TWENTY-EIGHT	121
EXAMINATION TWENTY-NINE	123
EXAMINATION THIRTY	124



EXAMINATION ONE

1. Use a non – programmable scientific calculator to: -
- (a) Find z if $z = \frac{\sqrt{3.98} + \log_{3.1}(5.21)}{\ln(\log(43.1) \times e^{\log(3.2)})}$ correct to 4 significant figures
- (b) Evaluate $\sqrt{\left(\frac{\sqrt[5]{8.7 \times (7.8)^{-2}}}{\sqrt{8.7 - (5.7)^{-2}}}\right)}$ correct to 4 decimal places
- (c) If $k = \frac{(0.12)^{-3} \times \sqrt[4]{2.36}}{\tan(56.78)}$ and $p = \frac{e^{\log 23 + \ln 23}}{\ln(e^{-2.3} + 10^{-2.3})}$ find $Q = \frac{\sqrt{kp}}{k+p} + \frac{p-k}{\sqrt{kp}}$ correct to 4 decimal places.
2. (a) Sketch the graph of $f(x) = |x| + 1$ and state the domain and range of $f(x)$
- (b) If $f(x) = \ln(x+2)$ and $g(x) = e^{2x}$ find (i) $f \circ g(x)$ (ii) $g \circ f(x)$.
- (c) Sketch the graph of $f(x) = \begin{cases} x^2 - 1 & \text{if } x > 0 \\ -2 & \text{if } x \leq -1 \end{cases}$
3. (a) A lecture room has chairs arranged in lines; the fifth line has 60 chairs while the eleventh line has 24 chairs, find;
- (i) How many chairs are in the first line?
- (ii) It is given that the room has total of 594 chairs, how many chairs are in the last line?
- (b) Convert 3.4777... into fraction using sum to infinity formula.
- (c) An arithmetic progression has the sum of the 10th and 12th terms of is -31 and the sum of the 11th and 15th is -28, find the first term and the common difference.
4. (a) Prove that $\frac{d^2y}{dx^2} = 8y\sqrt{1-y^2}$ if $y = \tan(2x)$
- (b) Use logarithm or otherwise to differentiate $f(x) = (x+3)^4(2x-3)^5$
- (c) A demo cylindrical simtank with radius 10 cm, is leaking at the rate of 200π cm cubic every minute. Find the rate of change of the height.
5. (a) Integrate $\int \frac{2x-3}{\sqrt{x^2-3x}} dx$



- (b) Calculate the area under the curve $y = -x + 1$ from $x = -1$ to $x = 3$.
- (c) Find the volume of a solid of revolution when $y = -x + 1$ from the intercept of x to $x = 4$.
6. (a) University of Oxford tested a COVID-19 vaccine to 100 people. These people were categorized in age groups as follows: -
- | | | | | | |
|-------------------|---------|---------|---------|---------|---------|
| Age(years) | 10 – 18 | 20 – 28 | 30 – 38 | 40 – 48 | 50 – 58 |
| No. of volunteers | 15 | 27 | 23 | 19 | 16 |
- (i) Use $A = 24$ as assumed mean value, calculate mean age by coding method.
- (ii) Calculate the positive difference between 80th percentile and the 75% quartile correct to 2 decimal places.
- (iii) Draw an ogive and estimate lower quartile and median.
- (b) It is given that mean of the following numbers are 7 find the values of x the numbers are: -
 $8 + x, 5, 7, 9 + 3x, 9, 4, 1, 9$.
7. (a) How many 4 digits even numbers can be formed using the digits: 1, 2, 3, 4, 5, 7.
- (i) If a number cannot end with 4 and digits are not repeating?
- (ii) How many numbers formed are greater than 3000, if digits may repeat?
- (b) If a family of 3 children, find the probability that the second child is a boy if the first is a girl.
- (c) Show that ${}^n C_r = {}^n C_{n-r}$
8. (a) Solve for x from -360° to 360° inclusive, from $\cos x + \cot x = 0$
- (b) Show that $\sin(A + B) + \sin(A - B) = 2\sin A \cos B$
- (c) Eliminate Y from $\begin{cases} q = \cos^2 Y \\ 1 - p = \tan Y \end{cases}$
9. (a) Find the inverses of $f(x) = 10^{2x-3}$ and $g(x) = \log_3(x - 2)$.
- (b) Find the asymptote of $y = \ln(x + 4)$ and hence sketch the graph of y .
- (c) The equation $V_t = 1905(0.735)^t$ gives the approximated value of an item t years after it is produced. Calculate: -
- (i) Depreciation percentage
- (ii) It is value 4 years after production



- (iii) Its value when new
10. (a) Name the matrix A with the property $AB = B$, where A and B are matrices of order $n \times n$.
- (b) Solve $\begin{cases} x + z = 10 \\ 2x - y + 3z = 21 \\ x + 2y = 9 \end{cases}$ by Cramer's rule
- (c) Maximize $f(x, y) = 3x + y$ from $\begin{cases} y \geq 1, x \geq 1, x \leq 3 \\ 2x + 3y \leq 8 \end{cases}$

EXAMINATION TWO

1. Use a non-programmable scientific calculator to:-
- (a) If $x = 3.21$, $y = 9.03$ $z = 2.09$ and $w = \frac{\sqrt{xz}}{y} + z$ find the value of $r = \sqrt{xy} + \sqrt[3]{wy} - \sqrt[5]{yz} + \sqrt[4]{3xwz}$ correct to five significant figures.
- (b) Find the value of $\left(\begin{pmatrix} 1 & 4 & 2 \\ 2 & 11 & 8 \\ 4 & 8 & 3 \end{pmatrix} \right)^{2.3}$ correct to three significant figures
- (c) Find mean and variance correct to three significant figures from
- | | | | | | | | | |
|-----|-----|-----|-----|-----|-----|-----|-----|-----|
| 8.1 | 3.2 | 4.2 | 5.3 | 8.9 | 6.7 | 5.4 | 6.2 | 9.2 |
| 5.4 | 4.4 | 6.6 | 2.5 | 8.4 | 4.9 | 5.5 | 3.9 | |
| 2.6 | | | | | | | | |
2. (a) A function is defined as $f(x) = \frac{2x+1}{x-1}$
- (i) The asymptotes of $f(x)$
 - (ii) The x and y intercepts of $f(x)$
 - (iii) Sketch the graph of $f(x)$
- (b) Given $g(x) = 2x^3 + x^2 - 5x + 2$ find
- (i) The roots of $g(x)$
 - (ii) Sketch the graph of $g(x)$
3. (a) Insert 5 arithmetic means between 7 and 17.2 and find the 100th term of this series.



- (b) The fourth, eighth and fifteenth terms of G.P forms three consecutive terms of an A.P, show that $r^4(r^7 - 2) = 1$
- (c) In an A.P the fourth, seventh and fourteenth terms are the three consecutive terms of G.P, and the 9th term of AP is 29, find
- The common ratio
 - The 4th term of A.P
4. (a) Use first principle of differentiation, prove that the derivative of a constant is zero.
- (b) Find the second derivative of $y = (3x^3 - 1)^5$
- (c) The cost function of producing x units of a certain product is given by the function $C(x) = 7500 + 100x - 0.03x^2 + 0.0004x^3$. Find the marginal cost of producing 1000 units of products.
5. (a) Integrate (i) $\int \left(\sqrt{x} + \frac{1}{\sqrt{x}} + 3x - 2 \right) dx$ (ii) $\int_1^2 \left(x^2 + \frac{3}{x^3} - x \right) dx$
- (b) If $\frac{dy}{dt} = 2t - 3$ find y at a point when $t = 0, y = 3$
- (c) Calculate the volume of solid of revolution when $3x^2 = y^2 - 5$ is revolved about:-
- About x – axis from $x = 2$ to $x = 3$
 - About y – axis from $y = 2$ to $y = 3$.
6. Given the histogram below

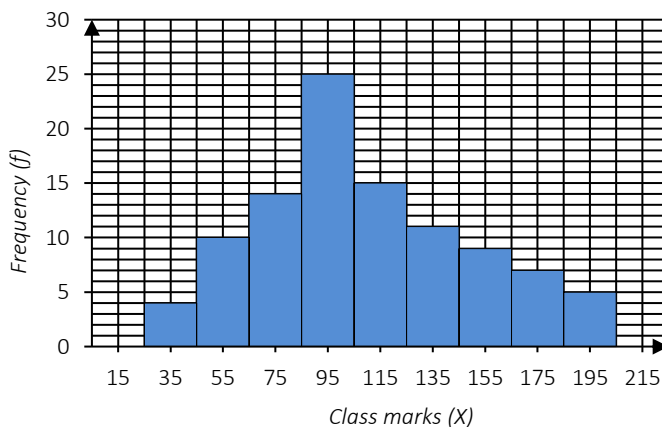

If the class interval is 10 and the class differences is 1 then

- Prepare a frequency distribution table
- Calculate median



- (c) Calculate mode
 (d) Calculate mean by assumed mean method, choose A from the modal class.
7. (a) In a box there are Red and Blue marbles, If the probability of drawing a blue and red or red and blue marbles is $\frac{23}{75}$

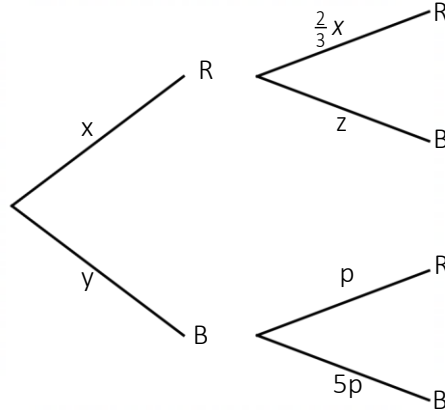

- (i) Find the value of x , y , z and p
 (ii) Find the probability of drawing two marbles of the same color.
- (b) In how many ways can 8 students sit in a circular table for their discussion?
 (c) In how many different ways can letters of the word MATHEMATICS be arranged so that the vowels always come together?
8. (a) Show that $\frac{\tan^2 x + 1}{\tan x \operatorname{cosec}^2 x} = \tan x$
 (b) Solve for x : $2 \sin^2 x = \cos x$ from $0^\circ \leq x \leq 360^\circ$
 (c) Eliminate p from: $\begin{cases} x = 1 - \sin(2p) \\ y = 1 + \cos(2p) \end{cases}$
9. (a) Sketch the graph of $y = 2^{x+1}$, state domain and range.
 (b) A TV set cost Tshs. 550,000 and depreciate at a rate of 12% per annum, find it is price after 4 years.
 (c) List two properties of graphs of exponential functions.
10. (a) Solve the following system of equations by Cramer's rule
- $$\begin{cases} 9x + 7y = 6 \\ x - 2y = 9 \end{cases}$$
- (b) A Farmer has 10 acres of land on which he can grow either maize or Wheat. He has 59 working days available during the cultivation season. Maize requires 5 days of labour per acre



while wheat requires 8 days of labour per acre. He also wants wheat not to exceed 8 acres. The cost of maintaining an acre of maize is Tshs 30000/= and that of wheat is Tshs 45000/=. How many acres of each crop should he plant to minimize the cost? What is the maximum profit?

EXAMINATION THREE

1. Use a scientific calculator to: -

(a) Evaluate $\log_e(2^4 + e^2 \ln 5) + \log_3 5$ correct to 6 significant figures.

(b) From the table below

Data (X)	0.398	0.467	0.577	0.687	0.898
Freq. (f)	10	25	30	20	15

Calculate

(i) Mean (to 3 decimal places)

(ii) Standard deviation (to 3 decimal places)

(c) Solve for x correct to 4 significant figures from $e^{2x} + 10e^x = \ln 3$

2. (a) Given $f(x) = 6x + 2$ and $g(x) = x^2 + 1$ find

(i) $f \circ g(x)$

(ii) $g \circ f(x)$

(b) Given the relation $h(x) = \begin{cases} 3 - x & \text{if } x > 1 \\ x^2 + 1 & \text{if } -1 \leq x \leq 1 \\ 2x & \text{if } x < 0 \end{cases}$

(i) Sketch the graph of $h(x)$

(ii) State the domain and range of $h(x)$

(iii) Find the value of $h(2) + h(\sqrt{3}) + 10h(0)$

3. (a) The first term of an arithmetic progression is 3, the 10th term is x and

the 16th term is $2x - 15$, if the common difference is y, find x and y.

(b) Solve for x, y and z from:
$$\begin{cases} x^2 + 3y + z = 10 \\ 2x - 3y - z = -2 \\ 3x - y + 2z = 11 \end{cases}$$

4. (a) Prove that $\frac{dy}{dx} = \sin(2x)$ if $y = \sin^2 x$



- (b) Differentiate $f(x) = x^x$ and show that $x = e^{-1}$ if $\frac{dy}{dx} = 0$
- (c) Air is being pumped into a rubber balloon; so that its radius increases at a rate of 0.17 mm each second, find the rate of increase of volume when radius is 0.7 cm.
5. (a) Evaluate (i) $\int (x-1)\sqrt{x^2-2x} dx$ (ii) $\int_0^{\pi/4} \tan x dx$
- (b) Find the area under the curve sketched below

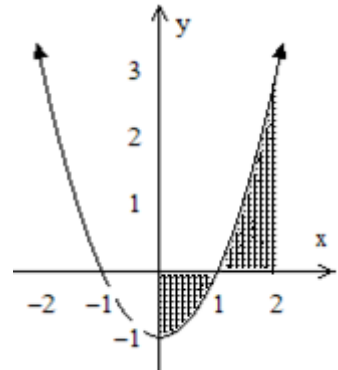

- (c) Find the volume generated when the curve $f(x) = 2\sqrt{x} + 3x$ from $x = 1$ to $x = 4$.
6. (a) From the set of numbers below,
- | | | | |
|----|----|----|----|
| 34 | 78 | 99 | 56 |
| 77 | 45 | 66 | 34 |
- 24.

Find (i) Semi-Interquartile range
 (ii) The 45th percentile

- (b) In a certain area, 100 people were tested randomly for COVID-19.

The following frequency distribution table summarize their ages.

Ages	12 – 19	22 – 29	32 – 39	42 – 49	52 – 59	62 – 69
Frequency	11	15	20	25	19	10

From the table below

Calculate

- (i) Lower Quartile
 (ii) Mean by coding method, use $A = 35.5$
7. (a) Liana has three pair of socks in a box, one morning she picked 2 socks at random, what is the probability that: -
- (i) She picked a matched pair?
 (ii) She picked unmatched pair?
- (b) Find the value of n from: ${}^n C_{n-2} + {}^n C_2 = 72$
- (c) In a class of 30 students, 18 are girls and 12 are boys. 10 Students are chosen at random to form a group,
- (i) In how many ways can 6 boys and 4 girls be obtained in this class



- (ii) What is the probability that there are 6 boys and 4 girls in a group?
8. (a) Solve for θ from: $8 \sin^2 \theta \cos \theta - \cos^2 \theta - 7 \cos \theta = 0$ from $0^\circ \leq \theta \leq 360^\circ$
- (b) Prove that $\tan(A+B) = \frac{\tan A + \tan B}{1 - \tan A \tan B}$
- (c) From the triangle ABC below
- Find the angles B and C
 - Find the length of AB
 - Area of triangle ABC
9. (a) Sketch the graph of $f(x) = \log x$ and $g(x) = 10^x$ on the same axis.
- (b) The equation $V = 46000 (0.76)^t$ describes the value of an item t years after purchase.
- What was the initial price of the item?
 - What is the rate of depreciation?
 - What will be the value of the item 8 years after purchase?

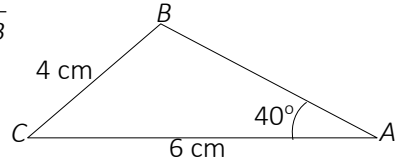

10. (a) From $C = \begin{pmatrix} 2 & 8 & -1 \\ 7 & 1 & 12 \\ 3 & 2 & 1 \end{pmatrix}$ find
- Determinant of C
 - Adjoint of matrix C

- (b) Sketch the following inequalities: $\begin{cases} 5x + 6y \geq 30 \\ x \leq 5 \\ 2x - y \geq 2 \end{cases}$



EXAMINATION FOUR

1. Use a non – programmable scientific calculator to: -

(a) From the frequency distribution table below

Data	0.78	1.08	1.46	3.82	4.78	5.32
	1	9	7	7	9	8
Frequency	8	16	20	26	17	13
y						

(i) Calculate $\sqrt{\frac{\bar{x} + 3\sigma}{\bar{x}\sigma}}$ correct to 3 decimal places

(ii) $\sum x^2 - \sum x$ correct to 3 decimal places

(b) Solve for y from $6e^{2y} - 37e^y + 56 = 0$ correct to 4 decimal places.

(c) Given $X = \frac{9.49 + (2.28)^{2.4} - (4.82)^{1.9}}{\sqrt[3]{9.49} + \sqrt[2]{2.28} - \sqrt[1]{4.82}}$ and

$$y = \sqrt[3]{\frac{\sin^{-1}(0.4351) + \cos^{-1}(0.8872)}{\tan^{-1}(2.9778) + \cot^{-1}(0.7823)}} \quad \text{find } \frac{y+x}{x-\sqrt{y}} \text{ correct to}$$

4 decimal places.

2. (a) Find a degree 4 function such that if $f(-2)=7$, $f(0)=3$, $f(1)=4$ and $f(2)=23$.

(b) Sketch graph of $f(x) = \frac{2-x}{x-1}$ State the domain and range of

$f(x)$

(c) Is $y^2 = 2x - 9$ a function? Give reason(s) and hence state the domain and range.

3. (a) A man left Tshs. 100 to be divided between his two sons Alfred and

Benjamin. If one-third of Alfred's legacy be taken from one-fourth of

Benjamin's, the remainder would be Tshs. 11. What was the amount

of each legacy?

(b) In an arithmetic progression, the sum of the first ten terms is 400 and the sum of the next ten terms is 1000. Find the common difference and the first term.

(c) 9 workers working 8 hours a day to complete a piece of work in 52 days. How long will it take 13 workers to complete the same job by working 6 hours a day.



4. (a) Describe the stationary point(s) of the curve

$$f(x) = x^3 - 3x + 2 \text{ and}$$

hence sketch it.

(b) Differentiate $y = \frac{2x+1}{\sqrt{x^2+2}}$

- (c) An upturned cone with semi vertical angle 45° is being filled with water at a constant rate of 30 cm^3 per second.

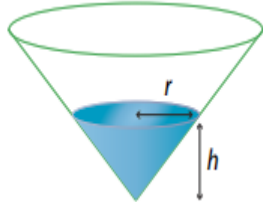

When the depth of the water is 5 cm, find the rate at which

- h , the depth of the water, is increasing
- r , the radius of the surface of the water, is increasing
- S , the area of the water surface, is increasing

5. (a) Integrate $\int \frac{e^x}{(e^x - 2)} dx$

(b) Integrate $\int \frac{x^2 - 1}{x^4 + 2x^2 + 1} dx$

(c) Calculate the area between $y = \sqrt{x} - 1$ and $y = x - 1$

6. (a) The age distribution of the population of a small village is recorded in the table below: -

Age (years)	$0 <$	$15 <$	$30 <$	$45 <$	$60 <$	$75 <$
No. of people	54	70	115	80	60	21

- Calculate mean correct to 2 decimal places
 - Calculate standard deviation correct to 2 decimal places
 - Calculate interquartile range of the distribution.
- (b) List 3 measure of positions in statistics
7. (a) The probability that Prisca goes club is 0.67, when she goes club, the probability that she takes biscuits is 0.46, when she did not go club the probability that she takes biscuits is 0.58. Calculate the probability that: -
- Prisca went club and did not take biscuits.



- (ii) Prisca takes biscuits.
- (b) A bag has 30 marbles in which 18 are red and the rest are green, 4 marbles were drawn from the bag: -
- A. Without replacement
- (i) Calculate the probability that at least 3 were green marbles
- (ii) Calculate the probability that at most 3 were red marbles.
- B. With replacement
- (i) Calculate the probability that no red marbles is chosen
- (ii) Two marbles were red
8. (a) Show that $\cos^4 \theta - \sin^4 \theta = \cos 2\theta$
- (b) If $2\cos^2 \theta + 4\sin \theta \cos \theta = a \sin 2\theta + b \cos 2\theta + c$ find a , b and c
- (c) Solve for x : $\tan^2 x - 3 \sec x = -3$ from $0 \leq x \leq 2\pi$.
9. (a) Masantula deposited Tshs 4000 into an account paying 6% interest compounded quarterly: -
- (i) How much money will be in Masantula's account after 5 years?
- (ii) What is the interest obtained?
- (b) Prove that if $a = b^x$, $b = c^y$ and $c = a^z$ then $d = a^{1/xyz}$
- (c) A population is increasing at the rate of 8% of the present population every year. If 4 years ago the population was 98100 people, what will be the population 4 years to come?
10. (a) Prove that
$$\begin{vmatrix} 0 & ab^2 & ac^2 \\ a^2b & 0 & bc^2 \\ a^2c & b^2c & 0 \end{vmatrix} = 2(abc)^3$$
- (b) The factory makes two types of products, A and B. Product A requires 3 and 5 hours in machine A and B respectively while product B requires 3 and 2 hours in machine A and B respectively. There are 36 available hours for making product A and 27 hours for making product B. If the costs of running machine A is Tshs 2000 per day and machine B Tshs. 2500 per day. How should the machines be run to minimize the cost? What is the minimum cost?



EXAMINATION FIVE

1. Use a scientific calculator to: -

(a) Find the value of $\sqrt{\frac{(9.27)^2 \times \ln(8.38) \div (4.82)^3}{\log(4.31) \times \ln(5.28) \div \sqrt{3.33}}}$ correct to 5

decimal places.

(b) Write down the expression or a number resulting when following these steps in your scientific calculator Casio fx-991MS.

(i) [mode] → [mode] → [mode] → [2] → [shift] → [4] → [1] → [1] → [2] → [=] → [2] → [=] → [8] → [=] → [1] → [=] → [2] → [=] → [3] → [=].

(ii) [mode] → [mode] → [mode] → [2] → [shift] → [4] → [1] → [1] → [2] → [=] → [2] → [=] → [8] → [=] → [1] → [=] → [2] → [=] → [3] → [=] → [shift] → [4] → [↵] → [1] → [shift] → [4] → [3] → [1] → [=].

2. (a) Given $f(x) = x + 3$, $h(x) = x^2 - 3x$ and $f \circ g(x) = 3x + 7$ find

(i) $g \circ h(x)$ (ii) $h \circ g(x)$

(b) Determine the domain and range of $y = \ln(2x - 3)$ and its asymptote

(c) Given $f(x) = \frac{3}{2x + 5}$ and $g(x) = 2x - 1$ find the domain of

$$f \circ g \circ f(x)$$

3. (a) A 40-year build program for houses began in Fort Jesus Empire in the beginning of year 1861 and finished in 1900. The numbers of houses built each year form an arithmetic sequence. Given that 2400 houses were built in 1870 and 600 houses were built in 1900, find: -

(i) How many houses were built in the first ten years?

(ii) The total number of houses built over a period of 40 years.

(iii) If the plan goes up to 50 years, how many houses could have been built in 50th year?

(b) The sum of n terms a series is given by $S_n = 3^n + 2n$

(i) Find the 3rd and 5th terms of this series

(ii) Is the series arithmetic or geometric?

(c) Simplify $\frac{\log 2 + \log 6 + \log 5}{\log 4 + \log 5 - \log 2 + \log 6}$

4. (a) Differentiate $g(x) = (x^2 + 3)(x^2 - 4x)$



- (b) Differentiate $y = \frac{2x-1}{x+3}$ by first principle of differentiation
- (c) A point P is moving along the curve whose equation is $y = \sqrt{x^3 + 54}$. When P is at (3, 9), y is increasing at the rate of 2 units per second. How fast is x changing?
5. (a) Evaluate $\int \frac{1+2x+2x^2}{\sqrt{x}} dx$
- (b) Find the equation of the curve if $\frac{dy}{dx} = 2x - 3x^2$ and passes through the point (1, 1).
- (c) If $\frac{d^2y}{dx^2} = 4 + \frac{1}{x^2}$ and $\frac{dy}{dx} = 2$ when $x = 1$ find y as a function of x, given $y = 2$ when $x = 1$
6. In a school of 88 students, the results of the examination are shown in the table below.
- | | | | | | | |
|-------|-----|------|------|------|------|------|
| Score | 0 > | 15 > | 30 > | 45 > | 60 > | 75 > |
| Freq. | 9 | 10 | 15 | 30 | 17 | 7 |
- (a) Calculate mean by coding method, use $A = 52.5$
- (b) Calculate median
- (c) Calculate mode
- (d) Calculate standard deviation by coding method, use $A = 52.5$
7. (a) A school has three photographers A, B and C. On any given day the independent probabilities of being absent are 0.1, 0.05 and 0.04 for A, B and C respectively. For a randomly chosen day, calculate the probability that: -
- At least one photographer was absent,
 - Exactly one photographer was absent,
 - Given exactly one photographer was absent, then he is C.
- (b) If A and B are independent events such that $P(A) = 0.69$ and $P(B) = 0.14$, find $P(A \cup B)$.
- (c) There are 10 woman and 15 men in an office. In how many ways can a team of 3 men and 2 women be selected?
8. (a) Prove sine rule for any triangle with sides a , b and c .
- (b) Use the rule proved above with the help of a right-angled triangle, prove the Pythagoras theorem.



- (c) In triangle ABC, $AB = 9.31\text{cm}$ $BC = 7.34\text{cm}$ and $AC = 11.2\text{cm}$. Calculate the size of angles of this triangle correct to 1 decimal place.
9. (a) Show that $\log_x(x^2 - a^2) = 2 + \log_x\left(1 - \frac{a^2}{x^2}\right)$
- (b) Solve for x : $\log_x 8 - \log_{x^2} 16 = 1$
- (c) Find the inverse of $y = \log_5(x^2 + 3)$ and state the domain of inverse obtained.
10. (a) Two types of foodstuffs A and B contain the number of units of protein and starch per kilogram as shown in the table below

	Units of protein	Units of starch	Cost per kilogram
A	4	5	350
B	6	3	450

If the daily intake from these foodstuffs is to be at least 16 units of protein and 11 units of starch, what is the most economical way of satisfying the conditions?

- (b) Given $A = \begin{pmatrix} 9 & 6 \\ 2 & 3 \end{pmatrix}$ and $B = \begin{pmatrix} 2 & -3 \\ 4 & 1 \end{pmatrix}$ show that

$$(AB)^{-1} = B^{-1}A^{-1}$$

- (c) Solve for p and q using matrix method $\begin{cases} 3p + 4q = 10 \\ 0.4p - 2.4q = 16 \end{cases}$

EXAMINATION SIX

1. Use a scientific calculator to: -
- (a) Evaluate $\frac{d}{dx} \left(\sqrt{x} + \ln(2x-1) + \sqrt[3]{x^3-2} \right)_{x=1}$ correct to 1 decimal place.
- (b) Evaluate $\int_1^2 \frac{\sqrt[3]{x+2}}{x\sqrt{3-x}} dx$ correct to 3 decimal places.
- (c) Given
- | | | | | | |
|------|------|------|------|------|------|
| 8.29 | 3.42 | 8.32 | 9.32 | 7.67 | 4.98 |
| 3.99 | 4.78 | | | | |
- Find (i) Mean (ii) Standard deviation (iii) Variance, all answers must be correct to two decimal places.



2. (a) Sketch the graph of $f(x) = \frac{x}{2x-3}$, for what values of x and y is $f(x)$ defined?
- (b) Given $f(x) = 2x^3 + 3x^2 + cx + 1$ if α , β and γ are roots of $f(x)$ such that $\alpha\beta + \alpha\gamma + \beta\gamma = 8/3$
- Find c .
 - Find the new equation with roots $\frac{1}{\alpha}$, $\frac{1}{\beta}$ and $\frac{1}{\gamma}$
3. (a) A geometric progression has the first term a , common ratio r and sum to infinity 6. A second geometric progression has first term $2a$, common ratio r^2 and sum to infinity 7. Find the value of a and r .
- (b) y varies partly as the square root of x and partly as the square of z . Given that $y = 11$ when $x = 9$ and $z = 2$, find
- The formula giving y in terms of x and z
 - The value of x when $y = 22$ and $z = 1$.
- (c) Solve for x from $5^{2x} - 11(5^x) = -10$
4. (a) Use first principle of differentiation to show that if $y = e^{2x}$ then $\frac{dy}{dx} = 2e^{2x}$
- (b) Find $\frac{dy}{dx}$ from $y^3 + 2x^2 = 3(x^2 + y^2)^3$
- (c) A water tank has the shape of an inverted right circular cone with its axis vertical and vertex lowermost. Its semi-vertical angle is $\tan^{-1}(0.5)$. Water is poured into it at a constant rate of 5 cubic metre per hour. Find the rate at which the level of the water is rising at the instant when the depth of water in the tank is 4 m.
5. (a) Evaluate $\int \frac{xe^{x^2}}{e^{x^2} + 3} dx$
- (b) Show that $\int_0^1 \frac{dx}{\sqrt{3-2x}} = \sqrt{3} - 1$
- (c) Find the area between the curve $y = x(6-x)$ and the line $y = 5$.



6. The grouped frequency distribution records the masses, to the nearest gram, of 84 letters delivered by the mail carrier.

Masses	1 – 20	21 – 40	41 – 60	61 – 80	81 – 100
No. of letters	10	18	24	14	18

Calculate

- Calculate Mode
 - Calculate Median
 - Calculate Mean by coding method, use $A = 50.5$
 - Draw an ogive and estimates quartiles.
7. (a) Bag A contain 30 balls, in which 20 are green and 10 are red balls. Bag B contain 45 balls in which 25 are green and 20 are red balls. One ball is drawn from bag A without noticing its colour and added to bag B , then two balls were drawn from bag B without replacement, find the probability that: -
- The ball drawn from bag A is a red ball
 - What is the probability that the balls drawn from bag B are of different colour?
- (b) A and B are two events such that $P(A|B) = 0.41$, $P(B) = 0.25$, and $P(A) = 0.22$. Find (i) $P(A \cap B)$ (ii) $P(B|A)$ (iii) $P(A \cup B)$
- (c) A marathon is attended by 25 people and three awards were prepared: first award is worth Tshs 10 million, the second is worth Tshs 5 million and the third is worth Tshs 3 million. If no person receives more than one award, how many different ways can the first three places be awarded?
8. (a) Prove that $\sin \theta = \frac{2t}{1+t^2}$ if $t = \tan(\theta/2)$, hence find $\tan \theta$ in terms of t .
- (b) Prove that $\cos 3A = 4 \cos^3 A - 3 \cos A$. Solve the equation $\cos 3A + 2 \cos A = 0$, giving all solutions between 0 and 2π
- (c) Given $f(A) = \frac{\cos A}{1 + \sin A} + \frac{1 + \sin A}{\cos A}$ show that $f(A) = 2 \sec A$ hence solve the equation $f(A) = 3$ between -2π and 2π .
9. (a) Sketch the graph of $y = e^x$ and $y = e^{-x}$ on the same axes.
- (b) If the principal is Tshs. 50,000 and the interest rate is 6% compounded semiannually for the first five years and 8% compounded quarterly for the next six years, what is the compound amount at the end of investment period?



- (c) A piece of land appreciates at the rate of 18% per annum; if the initial price was Tshs. 705,000 find its price at the end of 4th year.
10. (a) Define the following terminologies as used in linear programming: -
- Feasible region
 - Bounded feasible region
 - Optimal solution
- (b) A wheat and barley farmer have 168 hectares of ploughed land, and a capital of Tshs. 2000. It costs Tshs. 14 to sow one-hectare wheat and Tshs. 10 to sow one hectare of barley. Suppose that his profit is Tshs. 80 per hectare of wheat and Tshs. 55 per hectare of barley. Find the optimal number of hectares of wheat and barley that must be ploughed in order to maximize profit? What is the maximum profit?

EXAMINATION SEVEN

1. Use a non-programmable calculator to: -
- (a) Find $x + 3y - z$ correct to 6 decimal places, if
- $$x = \frac{4.361 + \sqrt{3.4781}}{e^{3.4781} + \ln(3.4781)}, \quad y = \sqrt[3]{\frac{\cosh^{-1}(3) + \sinh^{-1}(2)}{4.368 \times \sqrt{6.3907}}} \quad \text{and}$$
- $$z = \tan^{-1}\left(\frac{2.4618 + 75.22}{3.481 - 1.289}\right)$$
- (b) Find K if $K = 2.379 + \sqrt{\frac{2.379 + (6.4738)^{0.2}}{(4.3168)^{3/2} \times 4.532}}$ correct to 6 decimal places
2. (a) Given $f(x) = 2x - 5$ and $g(x) = e^{3x}$ find (i) $f(g)$ (ii) $g \circ f(0)$
- (b) Sketch the graph of $h(x) = 3 + \frac{1}{x - 2}$
3. (a) Evaluate $\sum_{n=3}^7 \left[20 \left(n - \frac{3}{4} \right)^{1/n} \right]$ correct to 6 significant figures
- (b) Convert 0.69 into fraction using sum to infinity formula
- (c) The sum of n terms of a certain series is given by
- $$S_n = 2n^2 + 4n - 1$$
- (i) Find the first three terms of the series.



- (ii) Is a series arithmetic or geometric? Hence if the series had 100 terms find the sum of last 11 terms of the series.
4. (a) Use the first principle to differentiate $y = e^{2x}$
 (b) Describe the stationary points of the curve $y = x^3 + 3x^2 - 24x + 12$
 (c) If the demand equation for the manufacturer's product is $d(x) = 200 - 0.3x$, find the marginal revenue function and evaluate it when $x = 100$.
 (d) A cargo aircraft is rising vertically into the air. Then t seconds after it has taken off, its distance (in meters) from the ground is $s(t) = \frac{100t + t^3}{\sqrt{t^2 - 2t}}$. Find its velocity after 10 seconds in kilometers per hour.

5. (a) Evaluate (i) $\int_2^4 \frac{x}{\sqrt{x^2 + 3}} dx$ (ii) $\int (2x - 3)^{10} dx$

(b) Find the area enclosed by the curves below

6. (a) Given numbers

10	17	13	18	23	14
19	30	11	15	29	34

Find

- (i) 3rd quartile (ii) 40th percentile

(b) Given the table below

Class	0 – 19	20 – 39	40 – 59	60 – 79
Cum. Freq.	5	13	17	23

Calculate

- (i) Mode (ii) Median (iii) Variance

7. (a) If $P(A) = 0.3$, $P(B) = 0.5$ and $P(A \cup B) = 0.65$, show if A and B are independent events or not.
 (b) In how many ways can 9 women sit around a circular table for their meeting if clockwise and anti-clockwise arrangements are the same?
 (c) How many 4-letter words code can be formed from the word PROGRAM if letters are not repeating?

8. (a) Prove that $\tan(A + B) = \frac{\tan A + \tan B}{1 - \tan A \tan B}$ hence find the answer

of

$\tan(15^\circ)$ and leave your answer in surd form.

(b) Solve for x : $\cos(3x - 60^\circ) = \sin(x + 30^\circ)$ from $-360^\circ \leq x \leq 0^\circ$.

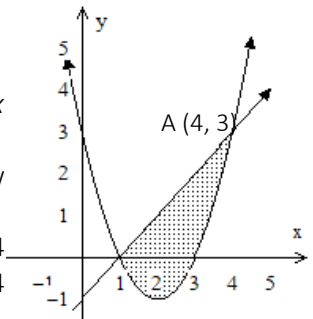

- (c) A student noticed that the angle of elevation of a cellphone tower from a certain point was found to be 70° , when she moved 10m away from the tower, she noticed that the angle of elevation decreased by 20° . Calculate
- How far was she at first, when the angle of elevation was 70°
 - The length of the cellphone tower
 - Angle of elevation when she is 100m away from the tower.
9. (a) Onesta invested a certain amount of money in bank Y, she found that after 4 years the amount became three times the money she invested, if the rate of interest was compounded semi-annually what was the rate of interest?
- (b) Use differentiation to prove that $\int e^{2x} dx = \frac{1}{2} e^{2x} + A$
10. (a) If $A = \begin{pmatrix} 1 & 2 \\ 3 & 0 \end{pmatrix}$, $B = \begin{pmatrix} 3 & 0 \\ 1 & 7 \end{pmatrix}$ and $C = \begin{pmatrix} 3 & 6 \\ 1 & 2 \end{pmatrix}$ show if $AB + AC = A(B + C)$
- (b) Solve by Cramer's rule: $-x + 3y - z = 80$, $2x - 3y - 2z = -20$ and $x + 2y + z = 60$.
- (c) A farmer wants to plant tomatoes and potatoes. Tomatoes needs 3 men per hectare and potatoes need also 3 men per hectare. He has 480 hired laborers available. To maintain a hectare of tomatoes needs 250 shillings while a hectare of potatoes costs him 100 shillings. Find the greatest possible area of land he can saw provided the farmer must grow the two crops, if he is prepared to use not more than 25,000 shillings for farming. What is the area to be used for tomatoes and potatoes?

EXAMINATION EIGHT

1. Use a scientific calculator to evaluate the following
- (a) Given the table below

Data	90	78	70	67	60	55	49	40	35
Freq.	20	30	45	60	90	78	52	35	20

Use the SD mode of your calculator to find

- Mean as an integer
- Standard deviation corrects to 4 decimal places



(iii) $\sum x$

(iv) $\sum x^2$

(b) Evaluate $\rho = \frac{\sqrt{T^X} + \sqrt{X^T}}{\sqrt{X^X} - \sqrt{T^T}}$ if $T = 2.34$ and $X = 4.32$ correct to

4
significant figures

(c) Solve the system of equations
$$\begin{cases} 20x + 50y - 30z = 2000 \\ 90x - y + 40z = 2950 \\ 100x - 300z = -7000 \end{cases}$$

2. (a) Given $f(x) = 4x - 9$ and $f \circ g(x) = \frac{9 - 14x}{2x - 1}$ find $g(x)$.
- (b) Sketch the graph of $h(x) = \frac{2 - x}{x - 3}$ and find the domain and range of $h(x)$.
3. (a) The sum of the first 7 terms of an arithmetic progression is with 30 terms is -14, the sum last 9 terms is -810 find
- The first term
 - The common difference
- (b) Use the sum to infinity formula convert 0.2343434... into fraction
- (c) The third, fifth and seventeenth terms of an arithmetic progression forms three consecutive terms of a geometric progression. Find the common ratio of the geometric progression.
4. (a) If $y = \sec(2x)$ show that $\frac{d^2y}{dx^2} = 4y(2y^2 - 1)$
- (b) Use the second derivative test to describe the nature of the stationary point of the curve $f(x) = 4x^3 - 3x^4$
- (c) The volume of air which is pumped into a rubber ball every second is $\pi \text{ cm}^3$ and its radius changes with increase of air, find the rate of change of the radius when radius is $1/4 \text{ cm}$.
5. (a) Evaluate $\int x\sqrt{2x - 1} dx$
- (b) Find the value of a if $\int_2^3 (ax + 3) dx = 18$
- (c) Find the volume generated when the region of the curve $y = x\sqrt{x + 3}$ is rotated once through the x axis from $x = -3$ to $x = 0$.



6. (a) Given numbers below

7.8 5.6 7.4 6.6 4.7 3.9 8.8 6.4
3.4.

Find

- (i) Median
(ii) Semi – interquartile range.

- (b) From the statistical table below

Data	32 – 37	42 – 47	52 – 57	62 – 67	72 – 77
Cum.	16	40	61	81	100
Freq.					

- (i) Use A from the median class to calculate mean by coding method
(ii) Calculate median correct to 4 significant figures.
(iii) Calculate mode correct to 2 decimal places.
(iv) Calculate the standard deviation correct to 3 decimal places.
7. (a) Evaluate without using calculator (i) ${}^{500}C_{498}$ (ii) ${}^{-5}P_2$
(b) The events A and B are such that $P(A)=0.5$, $P(B)=0.3$ and $P(A \cup B)=0.6$
(i) Find the value of $P(A \cap B)$
(ii) Show whether A and B are independent events or not.
(iii) Find the value of $P(B|A)$
- (c) How many different words can be formed by arranging the letters of the word KISULISULI?
8. (a) Solve for x : $\cos(x - 30^\circ) = \sin(2x + 18^\circ)$ from $-360^\circ \leq X \leq 360^\circ$

- (b) Simplify $\frac{1 + \cos A - \sin^2 A}{\sin A(1 + \cos A)}$ hence find the value of A if

$$\frac{1 + \cos A - \sin^2 A}{\sin A(1 + \cos A)} = \sqrt{3} \quad \text{given that } 0^\circ < A < 90^\circ$$

- (c) Eliminate θ from $\begin{cases} x + y = \sec \theta \\ 2xy = \tan^2 \theta \end{cases}$

9. (a) If $A = \begin{pmatrix} 1 & 0 \\ 2 & 1 \end{pmatrix}$ and $B = \begin{pmatrix} 5 & -3 \\ -13 & 8 \end{pmatrix}$ find show that

$$(AB)^{-1} = B^{-1}A^{-1}$$



(b) Given that $X = \begin{pmatrix} 3 & 1 \\ 0 & 2 \\ 8 & 1 \end{pmatrix}$ and $Y = \begin{pmatrix} 1 & 0 & -2 \\ -3 & 1 & 8 \\ 0 & -1 & 6 \end{pmatrix}$

(i) YX

(ii) XY

(c) Use Cramer's rule to find the value of b so that the value

of x is 3 from the system of equations
$$\begin{cases} 3x + y + bz = 8 \\ 3z + 3x - y = 14 \\ 4x + 3y = 15 \end{cases}$$

and hence find the values of y and z using Cramer's rule.

10. (a) Define the following terms as used in linear programming: -

(i) An objective function

(ii) A bounded feasible region

(iii) What is the use of non – negativity constraints in a linear programming problem?

(b) A calculator company produces a non-programmable calculator and a programmable calculator. Long-term projections indicate an expected demand of at least 100 non-programmable calculator and 80 programmable calculator each day. Because of limitations on production capacity, no more than 200 non-programmable calculator and 170 programmable calculators can be made daily. To satisfy a shipping contract, a total of at least 250 calculators must be shipped each day. If each non-programmable calculator sold results in a loss of \$10, but each programmable calculator produces a profit of \$80, how many of each type should be made daily to maximize net profit?



EXAMINATION NINE

- Use a non-programmable calculator to answer the following questions
 - Evaluate $\frac{[\ln(\ln 4.224)]^{3/11} + [\log(\ln 4.224)]^{4/13}}{e^{2.34 \ln(5)}}$ correct to 4 decimal places.
 - Perform the following commands on your calculator and write their expressions.
 - [shift] → [ln] → [3] → [x] → [ln] → [(] → [4] → [)] → [+] → [shift] → [√] → [7] → [+] → [3] → [shift] → [x^{-1}].
 - [(] → [4] → [$a \frac{b}{c}$] → [7] → [)] → [^] → [6] → [+] → [(] → [3] → [$a \frac{b}{c}$] → [5] → [)] → [^] → [8] → [+] → [9] → [^] → [4].
- Find the inverse of $f(x) = 3x^2 + 4$ and hence show that $f^{-1} \circ f(x) = \pm x$
 - Sketch the graph of $f(x) = \frac{x^2 + 1}{x^2 - 4}$ and state at which value(s) of x and y is $f(x)$ defined.
 - If $f(2) = 17$, $f(10) = 57$ and $f(x)$ is a linear function, find $f(x)$
- The 13th term of an arithmetic progression is four times the third term, the sum of the first four terms is -34 . Find the sum of the first 200 terms.
 - Simplify $\frac{9^{1/3} \times 27^{-1/2}}{3^{-1/6} \times 3^{-2/3}} + (27^{1/4} \times 3^{1/4} \times \sqrt{3})^2$
 - In arithmetic progression the first, fourth and eighth are second, fourth and fifth terms of geometric progression, find the possible value(s) of the common ratio of geometric progression.
- Use first principle of differentiation, differentiate $f(x) = 3 - x$ with respect to x .
 - Differentiate $x^4 y - y^5 + 3x^3 + 9 = 0$ with respect to x .

- (c) Use differentiation to determine the stationary points of the function $f(x) = 3x^3 - 3x^2$ hence describe the points.
5. (a) Find $\int \left(\frac{x-3}{x+7} \right) dx$
- (b) Evaluate $\int_1^2 (x+3)(x+6)^2 dx$
- (c) Find the area under the curve $f(x) = 3x^3 - 3x^2$ with the positive x -axis.
- (d) Find the volume generated when $y^2 = x+3$ is rotated one revolution from $x = -3$ to $x = 0$ correct to 2 decimal places.
6. (a) Given the frequency distribution table below

Intervals	12 – 16	20 – 24	28 – 32	36 – 40	44 – 48
Frequency	8	10	9	7	5

- (i) Calculate mean using coding method, use A from the median class
- (ii) Calculate median
- (iii) Calculate upper quartile.
- (iv) Draw a histogram and estimate mode.
- (b) Given numbers below
- | | | | | | | |
|----|----|----|----|----|----|----|
| 18 | 17 | 18 | 12 | 16 | 14 | 13 |
| 12 | 19 | 18 | 17 | 12 | 16 | 15 |
| 23 | 21 | | | | | |
- Calculate
- (i) Semi – interquartile range
- (ii) 50th percentile
7. (a) If $P(A) = 0.24$ and $P(B) = 0.18$ find
- (i) $P(A \cup B)$ if A and B are mutually exclusive events
- (ii) $P(A \cup B)$ if A and B are independent events.
- (b) How many three letter words can be formed by rearranging the letters of the word REFERENCES if letters are all different and R or E must be the first letter.
- (c) In Tanzania, cars are registered in the form of [T (three digits) (three letters)] (e.g. T989DTX) find how many cars licenses can be made if two letters are not used, zero cannot start, all numbers and letters may repeat?

EXAMINATION TEN

1. Use a non-programmable scientific calculator to evaluate the following expressions
- (a) If $k = \frac{\pi^{\sqrt{3}} + 3^{\sqrt{\pi}}}{\sqrt[3]{\pi} + \sqrt[4]{3}}$ and $p = \frac{3}{\sinh(2) + \cosh(2)}$ evaluate
- $$m = \sqrt{\frac{k^{-\pi}}{\pi^{-p}}} \text{ to 4 significant figures}$$
- (b) Solve for x , y and z from
$$\begin{cases} 3x + y + 3z = 50 \\ 2x - 3y + z = 55 \\ x + y + 5 = 0 \end{cases}$$
- (c) Solve for x : $\left(\frac{13}{e^5}\right)^x = 4$ correct to 4 decimal places
2. (a) Sketch the graph of $f(x) = \frac{3}{x+2}$
- (b) If $f(x) = x^2 + 3x - 9$, $g(x) = x + 3$ and $h(x) = -x - 6$ show that $f \circ g(x) = f \circ h(x)$
- (c) Given $f(x) = \begin{cases} x^2 + 1 & \text{if } x > 1 \\ 1 - x & \text{if } x < 1 \end{cases}$
- (i) Sketch the graph of $f(x)$
- (ii) State the domain and range of $f(x)$
3. (a) Use laws of logarithm to show that $abc = 1$ if $a = \log_b c$, $b = \log_c a$ and $c = \log_a b$
- (b) The first term of an A.P is 25, the third term is 19. Find the number of terms in the progression if its sum is 82.
- (c) Find two numbers whose arithmetic mean is 39 and the geometric mean is 15
- (d) Solve for x and y :
$$\begin{cases} x^2 - y = 14 \\ y - 6x = 2 \end{cases}$$
4. (a) Differentiate by first principle of differentiation $f(x) = \frac{2}{x^2 + 1}$
- (b) If $2x^3 - 5y^2 = 10x$ show that $y \frac{dy}{dx} = \frac{3}{5}x^2 - x$
- (c) Find the greatest rectangular area that can be enclosed by a 20 m fencing.

5. (a) Evaluate $\int \frac{dx}{\sqrt{x^2 - 5}}$
- (b) Find the area enclosed by the curve $y = \sin(2x)$, the x-axis and the ordinates $x = 0$ and $x = \pi/3$
- (c) Find the volume generated when $y^2 = x + 3$ is rotated about y-axis from $y = 1$ to $y = 2$, leave your answer with pie.
6. (a) Given the frequency distribution table below

Data	10 –	20 –	30 –	40 –	50 –	60 –
	20	30	40	50	60	70
Freq.	12	17	X	20	10	8
Cum. F	12	29	Y	82	92	100

Find

- (i) The value of X and Y
- (ii) Draw a frequency polygon
- (b) Given numbers:
6 9 8 14 13 10 7 9
5.
Calculate
- (i) Semi-interquartile range
- (ii) The 70th Percentile
- (iii) The 85th percentile
- (iv) The 30th percentile
7. (a) In how many ways can the letters of the word EXAMINATION be arranged so that E starts and O ends.
- (b) Students want to form their graduation committee, which should have 4 students. If there are 8 girls and 5 boys in this class, what is the probability that: -
- (i) There will be 3 girls
- (ii) There will be at least 2 boys
- (iii) No more than 2 girls
8. (a) Eliminate θ from $\begin{cases} x = 2 - \tan\theta \\ y = 3 + \sin 2\theta \end{cases}$
- (b) Solve for θ : $\tan\theta = 12\cot\theta - 4$ from $-\pi$ to π
- (c) In triangle ABC, $AB = 9\text{cm}$, $AC = 12\text{cm}$, and angle B is twice the size of angle C. Find angle C
9. (a) It is thought that a joke would spread in campus of 1800 people according to an exponential model $P = 5(1.247)^{0.32t}$, $t \geq 0$; where P.

is the number of people who have heard the joke, and t is the time in minutes after a joke is first told.

- (i) How many people heard the joke at first?
- (ii) How many people had heard a joke after 12 minutes?
- (iii) Estimate how long it would take for everybody in a campus to hear this joke.

(b) Re-write $2^{2x+3} - 2^{x+1} = 3$ in the form of $x = \log_a b + c$, find the values of a , b and c .

10. (a) Find the inverse of $Z = \begin{pmatrix} 2 & -1 & 0 \\ 1 & 1 & 3 \\ 0 & 2 & -1 \end{pmatrix}$ and prove that $ZZ^{-1} = I$

where I is the identity matrix.

(b) The values of a for which K is singular matrix:

$$K = \begin{pmatrix} a & 2a & 0 \\ 0 & a & 1 \\ -1 & -1 & a \end{pmatrix}$$

EXAMINATION ELEVEN

1. Use a scientific calculator to: -

(a) Evaluate $3^{x+3} = 11$ correct to 3 decimal places

(b) Find the value of $\left(\frac{3.92 \times \sqrt{2.81} + (0.8938)^{0.2}}{\sqrt[3]{7.389} - \sqrt{0.3728}} \right)^{2.01}$ correct to 3 decimal places

(c) Find the determinant and inverse of $A = \begin{pmatrix} 6 & 3 & 2 \\ 4 & 5 & 8 \\ 7 & 9 & 5 \end{pmatrix}$

2. (a) A relation is defined as $f(x) = \begin{cases} -1 & \text{if } x < -2 \\ x-1 & \text{if } -2 \leq x < 2 \\ 2 & \text{otherwise} \end{cases}$

(i) Sketch the graph of $f(x)$ (ii) State the domain and range of $f(x)$

(b) Sketch the graph of $f(x) = x^3 - 3x^2$, from the graph describe the turning point(s).

3. (a) Solve for x and y from $\sqrt{x} - 3\sqrt{y} = -7$ and $3\sqrt{x} + 2\sqrt{y} = 12$

- (b) Solve for x : $\left| \frac{2}{x-1} \right| = 3$
- (c) The common ratio of the terms in a geometric series is 2^x .
- State the set of values of x for which the sum to infinity of the series exists.
 - If the first term of the series is 35, find the value of x for which the sum to infinity is 40.
4. (a) Differentiate $y = \sqrt{x^2 - \sqrt{x+1}}$
- (b) Given $y = (x^2 - 4x)^3$ find $\frac{dy}{dt}$ if $\frac{dx}{dt} = 3$ and $x = 3$
- (c) Approximate the square root of 4.089 using derivative concepts
5. (a) Evaluate (i) $\int \frac{\cos x}{3 + \sin x} dx$ (ii) $\int \frac{x^2}{x^2 + 1} dx$
- (b) Prove that $2 \int \frac{dx}{x} = \ln Ax^2$ where A is a constant of integration.
- (c) Find the area between $y = x^2 + 1$ and $y = 7 - x$
6. The scores of 54 students in basic applied mathematics were recorded as follows: -

89	67	34	56	29	77	56	88	32
66	38	99	36	88	36	37	44	56
62	46	49	37	33	43	73	75	37
39	64	44	91	63	72	67	28	45
49	47	98	37	83	36	79	63	73
56	33	54	57	32	73	93	73	27

- Prepare a frequency distribution table with intervals starting with 20 – 29, 30 – 39, etc.
 - From the frequency distribution table above calculate
 - Median
 - Mode
 - Variance
7. (a) The 11 tile letters PENULTIMATE are in a bag. Find the probability that, if eight letters are drawn at random and laid down in order, the word “ULTIMATE” is spelled.
- (b) In a family with three children, find the probability that the last two children are girls given that the first is a girl.
- (c) In how many ways can a family of 8 people sit around a round dining table for supper?

8. (a) Simplify $\frac{\sin^2 A}{1 + \cot^2 A} - \frac{\cos^2 A}{1 + \tan^2 A}$
 (b) Solve for A: $\tan A + \cot A = 3$ from 0 to 2π
 (c) Show that $\cot y - \cot x = \frac{\sin(x-y)}{\sin x \sin y}$
9. (a) A population of a certain town at any time is given by $P = 36700(2.3)^{0.31t}$ where t is time in years, find
 (i) What will the population of this town 4 years to come?
 (ii) When will the population double itself?
 (b) Draw the graph of $y = x^x$ for all $x > 0$
 (c) If $f(x) = 6^{\sqrt{x-1}}$ find $\frac{dy}{dx}$
10. A Chemicals company produces two types of photo-developing fluids. The first, a black-and-white picture chemical, costs Tshs. 2.5 million per ton to produce. The second, a color photo chemical, costs Tshs. 3 million per ton. Based on an analysis of current inventory levels and outstanding orders, production manager has specified that at least 30 tons of the black-and-white chemical and at least 20 tons of the color chemical must be produced during the next month. In addition, the manager notes that an existing inventory of a highly perishable raw material needed in both chemicals must be used within 30 days. To avoid wasting the expensive raw material, company must produce a total of at least 60 tons of the photo chemicals in the next month. What is the lowest possible cost of production?

EXAMINATION TWELVE

1. Use a scientific and a non – programmable calculator to: -
- (a) Evaluate $\frac{e^{\log(6.34)} + \sqrt{\ln \sqrt{\log(14.57)}}}{\log(\ln 2.92)}$ correct to 4 decimal places
- (b) Evaluate $\int_1^2 (2x + e^x) (\sqrt{x^2 + 1}) dx$ correct to 2 decimal places.
- (c) Write $34^\circ 33' 25'' + 2.189 \text{ rad}$ in radians correct to 4 decimal places.
2. (a) Consider the graph below

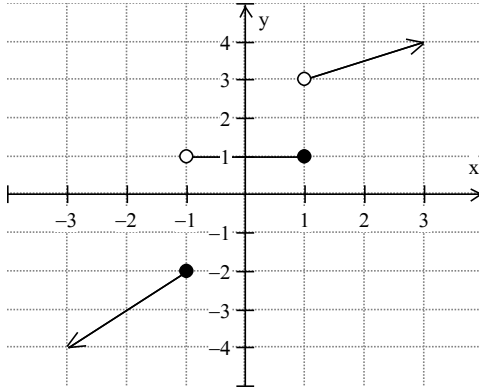

Find

- (i) $f(x)$
 - (ii) The domain and range of $f(x)$
- (b) A relation is defined as $y^2 = x - 2$,
- (i) Sketch the graph of the relation
 - (ii) State the domain and range of the relation
3. (a) In an A.P, the 7th term is half the third term and the 6th term is 10.
- (i) Show that the 11th term is zero
 - (ii) Find the common difference and the nth term.
- (b) When $f(x) = a(x+1) + b(x-1)(2x+3)$ is divided by $x - 2$ and $x + 3$ the remainders are 7 and 13, find the values of a and b
4. (a) Differentiate $y = \sqrt{\sin x} + \sqrt{\sin x} + \sqrt{\sin x} + \dots$
- (b) Find the square root of 9.95 using differentiation concept.
- (c) A farmer wants to fence an area of 1500 square meter in a rectangular field and then divide it in half with a fence parallel to one of the sides of the rectangle. Find the dimensions of the rectangle field.
5. (a) Evaluate $\int 3^{2x} dx$
- (b) Evaluate $\int \frac{2x^3 - 1}{x^4 - x} dx$
- (c) Find the area enclosed by the curve $y^2 = 9x$ and $y = x$
6. (a) In an experiment of measuring 80 leaves of a trees grown with a certain fertilizer, the results ae tabulated below.

Data	3.98	4.29	4.89	5.37	5.99	6.35	6.89
Freq.	9	13	15	18	14	11	8

Calculate

- (i) Mode
- (ii) Median
- (iii) Standard deviation

- (b) In a class with 50 students, the following scores were obtained in BAM test

20	34	40	54	62	22	34	43
55	67	23	35	45	56	67	23
36	45	56	67	24	37	45	56
73	25	37	48	56	77	28	37
49	57	82	30	37	50	59	83
32	39	52	60	84	34	39	53
62	89.						

- (i) Prepare a frequency distribution table with 5 class intervals.
 - (ii) Calculate median.
 - (iii) Calculate mean by assumed mean method, use A from modal class.
 - (iv) Calculate the mode.
7. (a) How many 4 letter words can be formed using the letters of the word "EQUATION"
- (i) If letters are not repeating.
 - (ii) If letters are repeating.
- (b) Define the following terminologies as used in probability
- (i) Events.
 - (ii) Sample space.
- (c) In an interview, roughly they were like 100 people who appeared for the announced posts, the quick observation showed that 65 were males and 35 were female. If 8 posts were required, calculate the probability that: -
- (i) Two males and six females were selected
 - (ii) Equal number of males and female were selected
 - (iii) No female selected
 - (iv) At least 7 females were selected
8. (a) A surveyor stood X meter away from the tower, and he observed the angle of elevation to be 67° , he then moved away Y meter away from the tower and he measured the angle of elevation to be 36° . If the height of the tower was 250m calculate the values of X and Y to one decimal place.
- (b) Solve for θ : $\sec(2\theta) = 3$ from -2π to 2π

- (c) Eliminate θ from
$$\begin{cases} X = 2 - 3\cos\theta \\ Y = 1 - 2\cot\theta \end{cases}$$
9. (a) State the domain and range of $y = \log_3(2-x)$
- (b) Use first principle of differentiation to prove that $\frac{dy}{dx} = 2^x \ln 2$
if $y = 2^x$ and $\lim_{h \rightarrow 0} \left(\frac{2^h - 1}{h} \right) \rightarrow \ln 2$
- (c) If $V_1 = V_0(0.67)^{0.3n}$ where V_i is a value at any time and V_0 is the initial value of the product and n is time in years, find
- The rate of product depreciation
 - For how long will the value of the product be $0.78V_0$?
10. (a) If $A = \begin{pmatrix} 1 & 3 & -2 \\ 2 & 1 & 4 \\ 3 & 2 & 1 \end{pmatrix}$ and $B = \begin{pmatrix} -7 & -7 & 14 \\ 10 & 7 & -8 \\ 1 & 7 & -5 \end{pmatrix}$ show that $AB=BA$
- (b) For what value(s) of k is $C = \begin{pmatrix} 1 & k-2 & 3 \\ 4 & k & 6 \\ 7 & 8 & 0 \end{pmatrix}$ a singular matrix?
- (c) Solve for x from
$$\begin{vmatrix} 2-x & 1 & -1 \\ 1 & -1-x & 2 \\ 8 & 2 & -1-x \end{vmatrix} = 0$$

EXAMINATION THIRTEEN

1. Use the scientific non-programmable calculator to: -
- (a) Determine the value of $\tau = \sqrt{\frac{\sqrt{\pi} + \tan^{-1}(3.2)}{\cos^{-1}(0.5311) - \sin^{-1}(0.2517)}}$
given your answer correct to 5 significant figures.
- (b) Given numbers:
9.23 4.28 3.48 4.20 8.29 8.99 5.32
6.54 3.29 3.89 2.98 7.23 5.44 7.45
2.91 4.23.
Calculate
- Mean
 - Standard deviation
 - Sum square of the data.
2. (a) Sketch the graph of $f(x) = \frac{x^2 - 1}{x^2 - 4}$ and hence find the domain and range of $f(x)$.

- (b) Determine a function with x – intercepts 3 and 1, hence find the y – intercept of this function.
- (c) Draw the graph of $n - 1 < x \leq n + 1$ for $n = -2, -1, 0, 1, 2, 3$.
3. (a) Solve for x and y :
$$\begin{cases} 2xy - 5y = 1 \\ 3x + y - 7 = xy \end{cases}$$
- (b) The sum of the first twenty terms of an arithmetic progression is 45, and the sum of the first forty terms is 290.
- (i) Find the first term and common difference.
- (ii) Find the number of terms in the progression, if with sum greater than 2000.
- (c) Given the series: 0, 1, 1, 2, 3, ... find out the 8th, 10th, 12th and 13th terms of this series.
4. (a) Differentiate by first principle of differentiation
 $f(x) = 4x^2 - \cos(2x)$
- (b) If $y = (\sin^{-1} x)^2$, show that $(1 - x^2) \frac{d^2y}{dx^2} - x \frac{dy}{dx} = 2$
- (c) If $x = \frac{2t}{t-2}$ and $y = \frac{3t}{t+1}$ find t when $\frac{dy}{dx} = 0$
5. (a) Evaluate $\int_1^2 (x+3)(x^2 + 6x - 1)^2 dx$
- (b) A racing motorcycle starts from rest and its acceleration after t seconds is $\left(k - \frac{1}{6}t\right) \text{ms}^{-2}$ until it reaches the velocity of 60 m/s at the end of 1 minute. Find the value of k , and the distance travelled in the first minute.
- (c) Find the area enclosed by the curves $y = 2x^2 - x^3$ and $y = x^2 - 2x$
6. (a) The marks of 100 students were tabulated in table below
- | | | | | | | |
|-------|------|------|------|------|------|------|
| Marks | 30 – | 40 – | 50 – | 60 – | 70 – | 80 – |
| | 39 | 49 | 59 | 69 | 79 | 89 |
| Freq. | 10 | 14 | 26 | 20 | 18 | 12 |
- (i) Use $A = 64.5$, calculate mean by coding method
- (ii) Calculate variance
- (b) The distribution of various types of land and water in a certain city.
- | | | | |
|------------|------------|-------------|-------------|
| Woodland | Urban | Farmland | Waterbodies |
| 660 sq. km | 540 sq. km | 1200 sq. km | 300sq. km |
- With appropriate measures represent this information in a pie chart

7. (a) Five husbands and their wives sit on a bench. In how many ways can they be arranged if: -
- There is no restriction,
 - Each husband and wife sit next to each other?
- (b) Letters of the word TERRORIST are written on cards and placed in an empty bucket. Two students were called to pick 2 cards from the bucket without replacement. What is the probability that: -
- Letters R and R were picked by students
 - Letter O first and S second were picked.
 - The second letter is T given the first letter is S.
8. (a) Prove that $2 \tan^{-1} x = \sin^{-1} \left(\frac{2x}{1+x^2} \right)$
- (b) In a triangle ABC, BC = 3.5 m, AC = 4 m and AB = 5 cm. Calculate the size of angle A and hence calculate the area of the triangle correct to 4 significant figures.
9. (a) If $y = \ln(x\sqrt{x+1})$ find $\frac{d^2y}{dx^2}$
- (b) Draw the graph of $f(x) = 1.2^x$ and $g(x) = 2^x$ on the same axes.
- (c) A radio sells for Tshs 550,000 and loses 5% of its value per year.
- Write down a function that the radio's value, $V(t)$, t years after it is sold.
 - Calculate the price of the radio 5 years after being sold.
10. (a) Solve the following linear programming problem graphically
Find the minimum value of $Z = 200x + 500y$ subject to the constraints:
- $$\begin{cases} x + 2y \geq 10 \\ 3x + 4y \leq 24 \\ x \geq 0, y \geq 0 \end{cases}$$
- (c) Find matrix C if $AB + C = A + BC$ given $A = \begin{pmatrix} 2 & 0 \\ 1 & 3 \end{pmatrix}$ and
- $$B = \begin{pmatrix} 3 & 2 \\ 7 & 1 \end{pmatrix}$$

EXAMINATION FOURTEEN

1. Use a non-programmable calculator to: -
- (a) Find the value of P if $P = \frac{\sqrt{3.928} + \sqrt[3]{2.737}}{\sqrt{\sqrt{8.361} + (0.467)^3}}$ to 3 decimal places
- (b) Find X such that $X = \left[\frac{{}^7C_3}{{}^9P_2} + \frac{(4!)^2}{(10! - 6!)} - \frac{{}^9P_4}{9!} \right]^{2.7}$ to 4 significant figures
- (c) From the numbers:
 9.3 8.8 6.7 6.9 9.2 7.1 5.4 4.5
 8.4 6.4 2.1 1.9 2.7 3.6 6.8 3.2
 Calculate (i) Mean correct to 4 significant figures
 (ii) Variance correct to 4 significant figures
2. (a) If $f(x) = ax + b$, show that $f^{-1} \circ f(x) = f \circ f^{-1}(x) = x$
- (b) A function is defined as $g(x) = \frac{1}{8}x^3 + 1$, find: -
 (i) The inverse of $g(x)$
 (ii) Domain and range of $g^{-1}(x)$
- (c) Sketch the graph of $f(x) = x^3 + 2x^2 + 5x - 6$.
3. (a) The sum of the first 20 terms of an arithmetic series is identical to the sum of the first 22 terms of another series with $A_1 = 1$. If the common difference of the two series is -2 , find the first term of the first series.
- (b) Solve for x from $\log(19x^2 + 4) - 2\log x - 2 = 0$
- (c) Solve for x from $3^{2+2x} - 28 \times 3^x + 3 = 0$
4. (a) If $x = \frac{2t}{2-t}$ and $y = \frac{3t^2}{2-t}$ find $\frac{dy}{dx}$
- (b) Differentiate $y = x \sin^{-1}(x)$
- (c) Find the maximum, minimum or inflexion point of the curve $y = x^4 + 32x$
5. (a) Integrate $\int_{\pi/6}^{\pi/2} \left(\frac{4 \cos x}{2 + \cos^2 x} \right) dx$
- (b) Integrate $\int 2^{x+1} dx$

- (c) Find the volume of solid of revolution when $y^2 = \frac{x}{x^2 + 3}$ is revolved about x – axis from $x = 2$ to $x = 5$.

6. (a) Given set of numbers:

7 8 9 2 8 7 5 8
 9 7 8 9 7 7 9 6
 9 0

Calculate

- (i) Semi Inter-Quartile Range (SIQR)
 (ii) The ratio of 70th and 40th percentiles
 (iii) Variance and standard deviation using assumed mean method, use $A = 7$

- (b) The frequency distribution table below summarize scores of 180 students in the Mock examination in Kiswahili subject.

Score	< 20	< 40	< 60	< 80	< 100
No of students	20	38	56	44	22

- (i) Calculate mean by assumed mean method
 (ii) Calculate mode (iii) Draw a histogram
7. (a) A police officer reported that a truck seen running away from the scene of the crime had a plate number that began with T, the digits 5, 4, and 9 and the end letters were T, D and B. He could not however remember the order of the digits or end letters. How many trucks would need to be checked to be sure of including the suspect truck?
- (b) If A and B are independent events, such that $P(A) = x + 0.1$, $P(B) = x + 0.3$ and $P(A \cap B) = 0.24$
- (i) Find the value of x (ii) Find $P(A \cup B)$ (iii) $P(A' | B')$
- (c) A marathon is attended by 25 people, at which three awards worth Tshs 4 million each are given away. Assuming no person receives more than one prize how many different ways can the first three places be awarded?
8. (a) If $\sec A = \frac{2}{\sqrt{3}}$ find $\frac{1 - \tan A + \operatorname{cosec} A}{1 + \cot A - \operatorname{cosec} A}$
- (b) Prove that $\frac{1 + \sin A - \cos A}{1 + \sin A + \cos A} = \tan\left(\frac{A}{2}\right)$
- (c) Solve for x : $15\cos^2 x + 7\cos x - 2 = 0$ for 0° to 360°
9. (a) In a bacteria colony, the bacteria available at any time t is given by the equation $P_n = P_0(0.733)^{n/2}$, when n is time in minutes. After 4 minutes, there were 880 bacteria.
- (i) How many bacteria were there at the beginning?

- (ii) How many bacteria will be there 20 minutes later?
 (iii) What is the rate of decay of these bacteria?
- (b) If $f(x) = \log_4(2x - 1)$ and $g(x) = \log_2 \sqrt{x + 3}$ find
- (i) $f \circ g(x)$
 (ii) $g^{-1} \circ f^{-1}(x)$
 (iii) Solve for x , if $f(x) = g(x)$
10. The company produces two products: bed mattresses and box springs. A prior contract requires that the firm produce at least 30 mattresses or box springs, in any combination, per week. In addition, union labor agreements demand that stitching machines be kept running at least 40 hours per week, which is one production period. Each box spring takes 2 hours of stitching time, and each mattress takes 1 hour on the machine. Each mattress produced costs Tshs. 20; each box spring costs Tshs. 24.
- (a) Formulate the inequalities an equation
 (b) How many of each product should be made to minimize cost
 (c) What is the minimum cost?

EXAMINATION FIFTEEN

1. Use a non – programmable scientific calculator to: -
 (a) Find mean and standard deviation correct to two decimal places

Data	291	299	310	329	338	367	371	396
Freq.	20	28	40	65	50	45	34	18

- (b) Evaluate $\frac{\log(\ln \sqrt{8.69} - e^{\log(\ln \sqrt{3.98})} + \log 43.5)}{\sqrt{\log \sqrt{\ln \sqrt{\log 8.38} + \ln 7.93}}}$ correct to 6 significant figures.
2. (a) Given $f(x) = \frac{a}{x} + b$, such that $f(-1) = 1.5$ and $f(2) = 9$ find the values of a and b hence find $f \circ f(x)$.
- (b) Sketch the graph of relations $R(x) = \{(x, y) : y > x^2 - 2x - 3\}$
3. (a) Find the coordinates of intersection of $\begin{cases} 3x^2 - 7y - 5 = 0 \\ 7x + 4y - 18 = 0 \end{cases}$

- (b) The sum of digits of a two-digit number is 11. When the digits are reversed, the number is increased by 45. Find number.
- (c) If q varies directly as the cube root of p and square of r , $p = 27$, $q = 2$ and $r = 4$ find
- The equation connecting p , q and r .
 - If q is 4 times r , find the relation connecting p and r .
4. (a) If $x = t^3 - 2t^2$ and $y = t^2 + 3t$ find $\frac{d^2y}{dx^2}$
- (b) Prove that $y \frac{d^2y}{dx^2} + \frac{dy}{dx} + 1 = 6(x + y)$ if $y = 3x^2 - x$
- (c) A father has a vegetable plot which is a rectangle with one side closed by an old wall. He has a piece of rope 5 m long, to mark out the part he wants. He wants to enclose the largest area possible. What dimensions would you advise him to use?
5. (a) Integrate $\int \left(2x + \frac{1}{x}\right)^3 dx$
- (b) The slope of the curve is $\frac{dy}{dx} = 4x - 12$
- The minimum value is 16. Find the corresponding value of x
 - Find the equation of the curve.
- (c) Find the area under the curve $f(x) = 4 + 4x^3$ from $x = -2$ to $x = 0$
6. (a) Given a set of five number 6, 3, 8, 5, 9. Two positive whole numbers, a and b , are to be added to this set of five numbers, such that the mean become 5.86 and the variable is become 3.8. Find a and b .
- (b) Given numbers
- | | | | | | | | |
|----|----|----|---|---|---|----|----|
| 12 | 3 | 6 | 5 | 3 | 8 | 14 | 20 |
| 19 | 24 | 9. | | | | | |
- Calculate
- Lower quartile
 - Upper quartile
 - 70th percentiles
 - 90th percentiles
7. (a) Six colored chairs are arranged in circular table so that clockwise and anti-clockwise moments arrangement is the same. How many possible arrangements are there?

- (b) Determine quotient and remainder when $P(x) = 2x^3 + 5x^2 - 3x + 10$ is divided by $Q(x) = x - 3$.
- (c) If the roots of the polynomial $2x^2 + 11x - 30$ are α and β find the value of (i) $\alpha^2 + \beta^2$ (ii) $\alpha^2 - \beta^2$.
3. (a) Solve the equation $\log_2 y^2 = 4 + \log_2(y + 5)$
- (b) Solve for x from $2^{2x+1} - 129(2^x) + 64 = 0$
- (c) Prove that sum of geometric progression is $S_n = G_1 \left(\frac{r^n - 1}{r - 1} \right)$ hence deduce the sum to infinity formula when $|r| < 1$
4. (a) Use the product rule of differentiation to prove the quotient rule of differentiation.
- (b) Differentiate $y = \frac{(x^2 - 5)^3}{(x + 2)^2}$
- (c) A stone is thrown upward. Its height at any time is given by $h = 30t - 6t^2$
- (i) Find the maximum height reached
- (ii) Sketch the graph of h against t .
5. (a) Integrate $\int_0^{\pi/3} (\sin 2x - \cos 4x) dx$
- (b) Find the volume generated when $y = \frac{\sqrt{x}}{(x^2 + 3)^{1/4}}$ is rotated about x - axis from $x = 0$ to $x = 1$.
6. Given a frequency distribution table below
- | | | | | | |
|-------|---------|---------|---------|---------|---------|
| Data | 10 – 19 | 20 – 29 | 30 – 39 | 40 – 49 | 50 – 59 |
| Freq. | 17 | 21 | 22 | 10 | 5 |
- Calculate
- (a) Median (b) Mode (c) Mean by coding method, use $A = 34.5$
- (d) Draw an ogive and estimate upper quartile.
7. (a) Mauled and Asia are about to sit for national examination this year. The probability that Mauled pass the exam is 0.45, Asia said her probability to pass is third quarter of Mauled to pass. If Mauled pass, he will go to university otherwise he will do a course in self-reliance. If Asia pass the examination she goes to university, otherwise she will study entrepreneur. Find the probability that: -
- (i) All will go to university

- (ii) Mauled will go to a self-reliance while Asia will go university
 (iii) At least one will go to university
- (b) How many numbers less than 4500 can be formed using the digits (zero is not starting): 0, 2, 3, 4, 5, 7, 8, 9 if digits are not repeating
8. (a) Show that $\sqrt{2 + \sqrt{2 + \sqrt{2 + 2\cos(8A)}}} = 2\cos A$
- (b) Show that $\cos^{-1}\left(\frac{3}{5}\right) + \cos^{-1}\left(\frac{4}{5}\right) = \sin^{-1}(1)$
- (c) In triangle ABC, $A = 35^\circ$, $b = 3$ cm and $c = 5$ cm, find the value of a and find the area of the triangle.
9. (a) After how many years will Tshs. 9000 amounts to Tshs. 20,000 if it is invested at 4.5% compounded semi-annually?
- (b) Sketch the graph of $y = \log_3(x^2+2)$ and state the domain and range.
10. A homemaker wishes to mix two types of food F1 and F2 in such a way that the vitamin contents of the mixture contain at least 8 units of vitamin A and 11 units of vitamin B. Food F1 costs 60/Kg and Food F2 costs 80/kg. Food F1 contains 3 units/kg of vitamin A and 5 units/kg of vitamin B while Food F2 contains 4 units/kg of vitamin A and 2 units/kg of vitamin B. Formulate this problem as a linear programming problem and minimize the cost of the mixtures.

EXAMINATION SEVENTEEN

-
1. Use a non – programmable scientific calculator to: -
- (a) Evaluate $\sinh^{-1}\left(\frac{\tan^{-1}(3.2811)\sin^{-1}(0.3718)}{\cos^{-1}(0.3405)\sec^{-1}(2.9371)}\right)$ correct to 3 decimal places
- (b) Evaluate $\frac{{}^{10}C_2}{{}^{15}P_3} + \frac{34!}{25!}$ correct to 3 significant figures.
- (c) Find the value of y if $5^{3x-1} = 16$ correct to 3 significant figures.
2. (a) Given $f(x) = \frac{ax+1}{bx+d}$ if the vertical asymptote is $x = -3$ and the x and y intercept is $\left(-\frac{1}{2}, 0\right)$ and $\left(0, \frac{1}{3}\right)$.
- (i) Find the values of a , b and d . (ii) Find the horizontal asymptote
- (b) If $f(x) = \sqrt{x-2}$ and $g(x) = 2x^2$ find $f \circ g(3)$
3. (a) By putting $y = x + \frac{1}{x}$, solve the equation

$$2x^4 - 9x^3 + 14x^2 - 9x + 2 = 0.$$

(b) Prove that $\frac{1}{\log_a abc} + \frac{1}{\log_b abc} + \frac{1}{\log_c abc} = 1$

(c) If $\frac{x-2}{(x+3)(x-4)} = \frac{A}{x+3} + \frac{B}{x-4}$ find the value A and B.

4. (a) Differentiate $y = \sqrt{\frac{1+\cos x}{1-\cos x}}$

(b) If $e^x y - \sin x = 0$ show that $\frac{d^2 y}{dx^2} + 2\frac{dy}{dx} + 2y = 0$

(c) A spherical balloon is being blown up so that its volume increases at a constant rate of $8.4\text{mm}^3/\text{s}$. Find the rate of increase of the radius when the volume of the balloon is 1120mm^3 .

5. (a) Evaluate $\int_0^{\pi/2} \frac{\cos x}{(4+\sin x)^3} dx$

(b) A particle, A, moves in a straight line with an acceleration of $\frac{1}{(t+3)^2}$ m/s² after t seconds. When $t = -2$, A is at rest at a point O on the line of motion. Find expressions for its velocity and its displacement from O at time t and when $t = 2$.

6. (a) A sample of 20 rods gave the following results for the length, x .
 $\sum fx = 997$, $\sum fx^2 = 49711$. Calculate

(i) Mean (ii) Variance

(ii) Find a number, y , which increases the mean by 2.

(iii) Find another number, k , which decrease the variance by 0.3.

(b) The scores form three students in English test were as follows: -

38	11	45	35	22	41	33	29	14
46	33	22	46	21	34	47	29	37
19	30	47	15	31	28	16	26	31
25	13	28	12	10	17	23	19	37
15	44	24	30	23	16	25	25	38
27	33	39	27	32	38	35	34	10

(i) Prepare frequency distribution table with only six class intervals.

(ii) Calculate the median score (iii) Calculate the upper quartile.

7. (a) How many numbers greater than 400 can be formed from the digits 2, 3, 4, 5, 6, 7.

(i) If digits may repeat? (ii) If no repartition of digits?

(b) Two events A and B are such that $P(A) = 0.1$, $P(B) = 0.4$ and $P(A \cup B) = 0.4$ and $P(A \cap B) = 0.3$ find $P(A)$

- (c) In how many ways can the letters of the word "DISMISSAL" be arranged if S is always the first letter?
8. (a) Eliminate θ from
$$\begin{cases} \tan\theta + \sin\theta = x \\ \tan\theta - \sin\theta = y \end{cases}$$
- (b) (i) Find the area of the triangle PQR below
(ii) Find the length of QP
9. (a) In how many years will Tshs. 10000 invested at 6% per year compound interest amount to Tshs. 15500?
(b) Sketch the graph of $f(x) = 2^{x+1}$ and $g(x) = 3^{x+1}$ on the same axes and find abscissa at a point where $f(x) = g(x)$.
10. A chicken farmer can buy a special food mix A at Kshs. 20 per Kg and special food mix B at Kshs. 40 per Kg. Each Kg of mix A contains 3000 units of nutrient N1 and 1000 units of nutrient N2; each Kg of mix B contains 4000 units of nutrient N1 and 4000 units of nutrient N2. If the minimum daily requirements for the chickens collectively are 36000 units of nutrient N1 and 20000 units of nutrient N2, how many of each food mix should be used each day to minimize daily food costs while meeting (or exceeding) the minimum daily nutrient requirements? What is the minimum daily cost?

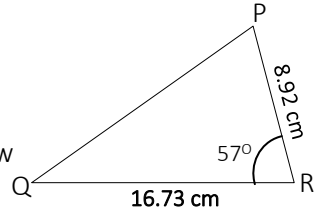

EXAMINATION EIGHTEEN

1. Use a non – programmable scientific calculator to: -
- (a) Evaluate $\int_2^7 \frac{dx}{\sqrt{x^3 + 3x - 5}}$ correct to 3 significant figures.
- (b) Evaluate $\frac{d}{dx} \left(\sqrt{x^3 + 3x - 5} \right)_{x=6}$ correct to 3 significant figures.
- (c) Evaluate $\sum_1^{10} (x \log(6^x))$ correct to 3 decimal places.
2. (a) A function is defined as
$$f(x) = \begin{cases} x+1 & \text{if } x < -1 \\ x^2 & \text{if } -1 \leq x < 1 \\ 2x & \text{if } x \geq 1 \end{cases}$$
- (i) Sketch the graph of $f(x)$
(ii) Is $f(x)$ a one to one function?
- (b) State the domain and range of $g(x) = \sqrt{\frac{2x+1}{x-4}}$
3. (a) Evaluate $\sum_2^5 (x+1)^3 \ln(x+2)$

- (b) A student bought a certain number of pencil for Tshs 2000/-. If each pencil had cost Tshs. 20 less, she could have bought five more pencils for the same money. How many pencils did she buy?
- (c) The resistance of motion of a car is proportional to the square of the speed of the car. If the resistance is 4000 newtons at a speed of 22.2m/s.
- What is the resistance at a speed of 30m/s?
 - At what speed is the resistance 6250 newtons?
4. (a) Differentiate $y = \sqrt{\frac{1-x^2}{1+x^2}}$
- (b) Differentiate $f(x) = \ln\left(\frac{x^5 + 2}{\sqrt{x}}\right)$
- (c) An open box is made from a square metal – sheet of cardboard, with sides half a metre long, by cutting out a square from each corner, folding up the sides and joining the cut edges. Find the maximum capacity of the box formed.
5. (a) Integrate $\int \frac{1}{\sqrt{x}(1+x)} dx$
- (b) Evaluate $\int_0^2 x^4(1+x)^4 dx$
- (c) Find the area generated when $y = x - 1$ is revolved about the $x -$ axis from $x = 1$ to $x = 3$.
6. Drug Control and Enforcement Authority in Australia measured the weight of 50 boxes of drug obtained during their operation as follows
- | | | | | | | | | |
|----|----|----|----|-----|----|----|----|----|
| 47 | 39 | 21 | 30 | 42 | 35 | 44 | 36 | 19 |
| 23 | 32 | 66 | 29 | 05 | 40 | 33 | 11 | 44 |
| 22 | 27 | 58 | 38 | 37 | 48 | 63 | 23 | 40 |
| 53 | 24 | 47 | 22 | 44 | 33 | 13 | 59 | 33 |
| 49 | 57 | 30 | 17 | 45 | 38 | 33 | 25 | 40 |
| 51 | 56 | 28 | 64 | 52. | | | | |
- Construct a frequency table starting with 0 – 9, 10 – 19, etc.
 - Calculate interquartile range
 - Calculate variance
 - Standard deviation.
7. (a) In a group of people, 10 are farmers, 15 are businessmen, 9 are both farmers and businessmen, every person in this group falls under these two categories. A person is chosen at random from the group, what is the probability that: -
- He is a farmer but not a businessman?

- (ii) He is a businessman only?
- (b) Solve for n : from ${}^{2n}C_3 - {}^nC_2 = 50$
8. (a) Show that $\tan A = \frac{p - \sqrt{3}}{1 + \sqrt{3}p}$ if $\tan(A + 60^\circ) = p$
- (b) Show that $\sin A \sin B = \frac{1}{2} [\cos(A - B) + \cos(A + B)]$ hence find the value $\sin 75^\circ \sin 15^\circ$
- (c) A 12m tall antenna sits on top of a building. A person is standing some distance away from the building. If the angle of elevation between the person and the top of the antenna is 60° and the angle of elevation between the person and the top of the building is 45° , how tall is the building and how far away is the person standing?
9. (a) The value of an item at any year is given by $V_t = V_0(1 - r)^{t/2}$ where V_t and V_0 are the current and initial values respectively. If $V_t = 4961$, $V_0 = 5000$ and $r = 0.78\%$, how old is this item?
- (b) Sketch the graph of $y = \frac{e^x + e^{-x}}{2}$ and state the domain and range.
10. (a) The first table shows points awarded by the judges in science fair competition for each category. The second table shows the difficulty of each category.

Table 1: Points Awarded

Contestant(s)	Originality of the project	Problem solving	Presenters appearance
St Jude	16.5	18	17.5
Makumira	12.5	14.0	17.0
St Joseph	16.0	19	18.0

Table 2: Degree of difficulty

Category	St Jude	Makumira	St Joseph
Originality of the project	2	3	2
Problem solving	3	3	1
Presenters appearance	2	2	1

- (i) Create matrices to organize the given information
- (ii) Find the total score for each contestant

(b) Given $f(A) = \begin{pmatrix} a-1 & 1 & a \\ 4 & 1 & 0 \\ 0 & 7 & a+1 \end{pmatrix}$, find a if $|f(A)| = -149$

EXAMINATION NINETEEN

1. Use a non – programmable scientific calculator to: -
 (a) Convert 5980 m into feet correct to 2 decimal places.

(b) Evaluate matrix C such that $AC = B$, if $A = \begin{pmatrix} 6 & 4 & 1 \\ 2 & 0 & 1 \\ 3 & 1 & 7 \end{pmatrix}$ and

$$B = \begin{pmatrix} 5 & 1 & 2 \\ 1 & 4 & 4 \\ 0 & 3 & 4 \end{pmatrix}$$

(c) Find the value of q correct to 3 decimal places, if $q = \sqrt[3]{\frac{2x+p}{z-k}}$,

$$x = 2.91 \quad p = 3.85, \quad z = 8.47 \quad \text{and} \quad k = 4.99$$

2. (a) A relation is defined as shown in a pictorial diagram below

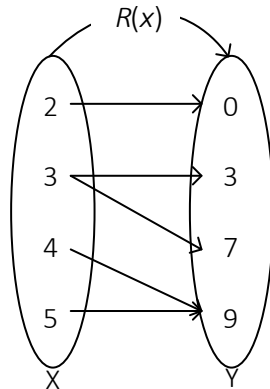

- (i) Is $R(x)$ a function? Why?
 (ii) Draw a pictorial diagram of $R^{-1}(x)$
- (b) If $f(x) = \sqrt{x-2}$ and $f \circ g(x) = \sqrt{x^2-1}$ find $g(x)$
- (c) Sketch the graph of $f(x) = \frac{2-x}{x+2}$
3. (a) Evaluate $\sum_{n=8}^{10} (-1)^n \left(\frac{n^2}{n-1} \right)$
- (b) Write $\frac{1}{7 \times 8} + \frac{5}{9 \times 16} + \frac{9}{11 \times 32} + \dots$ using sigma notation.
- (c) Convert 0.584848... into fraction using sum to infinity of geometric progression
4. (a) Differentiate $f(x) = \sqrt{\sin(x)}$

- (b) Prove by first principle that $\frac{dy}{dx} = e^x$ if $y = e^x$
- (c) A cube metal which is expanding uniformly as it is heated. At time t seconds, the length of each edge of the cube is x cm, and the volume of the cube is V cm³.
- Show that $\frac{dV}{dx} = 3x^2$
 - If the volume increases at a constant rate of 0.044 cm³/s, find the rate of change of the edge when $x = 2$ cm.
 - Find the rate of increase of the total surface area of the cube when $x = 2$ cm.

5. (a) Find the value of a from $\int_2^7 \frac{ax+1}{\sqrt{x+2}} dx = 28$

(b) Find the value of x from $\int \left(\sqrt{x} + \frac{1}{\sqrt{x}} + 3 \right) dx$

- (c) Find the volume of the solid of revolution of $y^2 = x^2 + 1$ from $x = 1$ to $x = 2$.

6. Given a frequency distribution table below

Class intervals	Frequency (f)
6.1 – 6.3	3
6.4 – 6.6	5
6.7 – 6.9	9
7.0 – 7.2	14
7.3 – 7.5	11
7.6 – 7.8	6
7.9 – 8.1	2

- Calculate variance
- Standard deviation
- Calculate Lower Quartile
- Calculate mean
- Calculate mode

7. (a) How many odd numbers greater than 3000 can be formed using digits 2, 3, 4, 5, 6 if digits are repeating.
- (b) Given that A and B are two events such that $P(A|B) = 0.3$, $P(B) = 0.18$ and $P(A) = 0.11$ find

- $P(A \cap B)$
- $P(B|A)$
- $P(A \cup B)$
- $P(A \cup B)'$

8. (a) If $A + B + C = 180^\circ$, prove that $\cos\left(\frac{A}{2}\right) = -\sin\left(\frac{B+C}{2}\right)$

(b) If $\sec A = \sqrt{3}$ find the value of $\frac{1 + \cos A + \operatorname{cosec} A}{1 + \sin A - \sec A}$

(c) Solve for x : $2 \sec x = \tan x - \cot x$ from 0° to 360°

9. (a) Given that $P = 60(0.751)^t$, find

- (i) The value of P when $t = 5.2$
 (ii) The value of t when $P = 27$
 (b) Find the least value of x if $1.8^{x+1} > 67$
 (c) State the domain of $f(x) = \log(\ln \sqrt{x+5})$
10. (a) Find matrix A and B such that $2A + B = \begin{pmatrix} 2 & 1 \\ 6 & 3 \end{pmatrix}$ and

$$3A - 2B = \begin{pmatrix} 8 & 1 \\ 3 & 2 \end{pmatrix}$$

(b) Verify that
$$\begin{vmatrix} 1 & a & bc \\ 1 & b & ac \\ 1 & c & ab \end{vmatrix} = \begin{vmatrix} 1 & a & a^2 \\ 1 & b & b^2 \\ 1 & c & c^2 \end{vmatrix}$$

EXAMINATION TWENTY

1. Use a non-programmable scientific calculator to: -
- (a) Evaluate $\frac{\sin^{-1}(\cos 58^\circ) + \tan^{-1}(\sec 48^\circ)}{\sin(\sin^{-1} 0.3412) + \tan(\sec^{-1} \sqrt{2})}$ correct to 4 decimal places
- (b) Evaluate $\sum_2^3 x^x \ln(2x+3)$ correct to 4 decimal places
- (c) Evaluate $\frac{13^\circ 15' 53'' + 2.1937 \text{ rad}}{\sin^{-1}(0.3618) - \tan^{-1} \sqrt{2}}$ give your answer to 4 decimal places.
2. (a) A function is defined as $g(x) = \begin{cases} x^2 + 1 & \text{if } x < 0 \\ -1 - x^2 & \text{if } x > 0 \end{cases}$
- (i) Sketch the graph of $g(x)$
 (ii) State the domain and range of $g(x)$
- (b) Given that $f \circ g(x) = x^2 + 3x$ and $f(x) = x - 2$ find $g \circ f(x)$
3. (a) Expand $\sum_2^\infty \left(\frac{x^2 + 2^x}{x-1} \right)$ up to the 5th term
- (b) The sum of three numbers is 66. The second number is twice the first and 6 less than the third. Find the numbers

- (c) Factorize completely $49p^2 - 28pq + 4q^2$
- (d) If $\frac{7a+2b}{3a-4b} = \frac{3}{8}$ find a/b
4. (a) Differentiate by first principle $y = \frac{1}{\sqrt{x}} + \sqrt{x}$
- (b) A curve $f(x) = ax^2 + bx + c$ has a stationary point at (1, 2) and crosses the vertical axis at the point (0, 3). Find the value of a , b and c .
- (c) A variable rectangle has a constant perimeter of 20 cm, find the dimensions of the sides when the area is maximum.
5. (a) Find the value of a if $\int_0^4 (ax-3)^4 dx = 336.8$
- (b) Find the volume generated when $y = \sin x$ is revolved about x - axis from $x = 0$ to 2π .
- (c) Find the area under the curve $y = \cos x$ from $x = 0$ to $x = 3\pi$
6. Complete the frequency distribution table below, $\sum f = 80$, $A = 40$ and class size is 10.

Class Intervals					
Frequency (f)					
Class mark (X)					
d					
fd					
u					
u^2	9	4	1	0	1
fu^2	90	72	24	0	12

Calculate

- (i) Median
- (ii) Mean by assumed mean method.
- (iii) Standard deviation by assumed mean method.
7. (a) If A and B are independent events such that $P(A) = 0.68$ and $P(B) = 0.21$, find $P(A \text{ or } B)$
- (b) In how many ways can a student make her own password from the letters of the word NENOLASIRI if letters are not repeating?
- (c) A fraction is formed by taking a numerator from {2, 3, 5} and denominator from {4, 6, 9} find the probability that: -
- (i) A fraction formed is greater than 1?
- (ii) A fraction formed is a half?
- (iii) A fraction formed is greater than a half?

8. (a) Show that if $\cot^{-1} x = \tan^{-1} \frac{1}{x}$
- (b) Simplify $\cot^{-1} \frac{1}{x} + \tan^{-1} x$
- (c) Solve the equation $\tan x \sin x = 0$ for -360° to 360° .
- (d) In a triangle ABC, AB = 20 cm, BC = 15 cm and angle B is 75°
- (i) Show that the area of the triangle ABC is $\frac{75}{\sqrt{2}}(\sqrt{3} + 1)$ square centimeters.
- (ii) Find the size of side AC to nearest centimeters
9. (a) Use graph to find values of x at a point of intersection of curve $y_1 = 2^x$ and $y_2 = 4x$ hence find the area enclosed between the curves.
- (b) Three guys, A, B and C invested money in three different banks with the rate of interest 10% quarter annually, 15% semi – annually and 20% annually. If A invested twice amount invested by C and C invested quarter amount invested by B, and at the end of two years, B got Tshs 1500/- interest: -
- (i) Find how much each invested
- (ii) Find the amount of A after 3 years
- (iii) Find the interest of C after 4 years
10. Nelson McKenzie produces two gift packages of fruit. Package A contains 20 peaches, 15 apples and 10 pears. Package B contains 10 peaches, 30 apples and 12 pears. Nelson McKenzie has 40 000 peaches, 60 000 apples and 27 000 pears available for packaging. The profit on package A is Kshs. 2.00 and the profit on B is Kshs. 2.50. If all fruit packaged can be sold, what number of packages of types A and B should be prepared to maximize the profit?

EXAMINATION TWENTY-ONE

1. (a) By using scientific calculator, evaluate

$$(i) \left(e^{\frac{2}{3}} + 16\cos(60^\circ) \right) \left(\sqrt{e^{\log 3} + \sqrt{\ln \sqrt{5e^4}}} \right)^{\frac{4}{5}} \text{ give your}$$

answer correct to 3 decimal places

$$(ii) \text{ Evaluate } \frac{\sqrt[4]{e^{-0.5} + 12\sin 12^\circ}}{\sqrt[3]{e^{0.8} \tan(60^\circ)}} \text{ give your answer correct to 4}$$

decimal places

- (b) Convert $56^\circ 45' 53''$ into radians correct to 3 significant figures.

- (c) The following data are the marks for Basic Applied Mathematics of 40 students of CBG from XY Secondary school.

32	31	27	30	29	27	25	29
26	26	32	24	31	31	27	24
26	26	32	33	29	33	28	26
33	24	28	32	32	24	31	27
30	31	25	27	30	26	29	25.

Use the scientific calculator to find

- The mean mark
- Standard deviation to 4 decimal places
- Variance to 4 decimal places

2. (a) Given the functions $f(x) = \sqrt{x}$ and $g(x) = 3x^2 - 2$ find

- $f \circ g(x)$
- $g \circ f(x)$
- Solve for x if $f \circ g(x) = g \circ f(x)$

(b) Sketch the graph of $f(x) = \frac{x^2}{x^2 - 4}$

- (c) The curve $y = ax^2 + bx + c$ passes through the points A(1,8), B(0,5) and C(3,20). Find the equation of the curve.

3. (a) Expand the following accordingly

$$(i) \sum_{n=1}^7 3^{n-1}$$

$$(ii) \sum_{n=2}^5 \left(\frac{n}{n-1} \right)$$

- (b) The sum of the first 20 terms of an arithmetic progression is 1660. Find the common difference of the progression, if the first term is seven.

- (c) X varies directly as the square of Y. $X = 4$ when $Y = 10$, find
- The equation connecting X and Y
 - The value of Y when $X = Y^2 - 1$

4. (a) Determine $\frac{dy}{dx}$ if $y = \frac{10x^2 - 7x^3 + 2}{6x^2 - 13}$ given $x = 2$

- (b) Find the equation of the tangent to the curve $y = e^{2x-1}$ at a point where $x = 0.5$

- (c) Describe the stationary point (s) of the curve $y = x^3 + 3x^2 + 3x + 2$

- (d) A certain manufacturing factory has a total cost function

$C(x) = x^3 - 6x^2 + 9x + 15$. Find the value of x when the total cost is optimum.

5. (a) Evaluate the integral $\int (2x - 1)\sqrt{x^2 - x} \, dx$

(b) Show that $\int_2^3 \left(\frac{1}{1+x} \right) \ln(1+x) \, dx = \frac{1}{2} \left(\ln \left(\frac{4}{3} \right) \right)^2$

- (c) Find the area of the region between $y = 4 - x^2$, $0 \leq x \leq 3$ and x-axis.

- (d) Find the volume of the solid of revolution $y = 2x + 3$ from $x = 0$ to $x = 3$

6. (a) Given numbers

34	43	23	45	35	43	22
36	42	44	39	27	29.	

Calculate

- Lower quartile
- Upper Quartile
- 50th Percentile
- 60th percentile

- (b) Find Variance and standard deviation from

Data	5.5 – 9.5	10.5 – 14.5	15.5 – 19.5	20.5 – 24.5
Freq.	12	38	33	17

7. (a) Evaluate the value of x if $(x+1)! = 6(x-1)!$

- (b) In how many ways can a football team of 11 players be selected from 16 players?

- (c) If A and B are independent events, show that $P(A \cap B) + P(A' \cap B) = P(B)$

- (d) In how many ways can you choose your tigo-pesa 4-digit PIN number if: -

- Digits may repeat?
- May not repeat?

(iii) What is the probability that there are no repeated digits?

8. (a) Prove that $\frac{\cos x}{1 - \sin x} = \frac{1 + \sin x}{\cos x}$
(b) Show that $\tan x = 1$ if $\cos(x + y) = \sin(x - y)$
(c) Solve for x between 0° to 360° inclusive, from $\tan x = 2 \sin x$
9. (a) Sketch the graph $f(x) = \begin{cases} 2^x & \text{if } x > 0 \\ 2^{-x} & \text{if } x < 0 \end{cases}$
(b) Eliminate constants from $t = Ae^{2x} + Be^{-2x}$
(c) Solve for x and y from $\begin{cases} \log x + \log y = 1 \\ x + y = 11 \end{cases}$
10. (a) If $\begin{pmatrix} a & -9 & 1 \\ 1 & b & 2 \\ -5 & 0 & -6 \end{pmatrix}$ and $\begin{pmatrix} -3ab & -54 & -23 \\ -4 & -7 & c \\ 5b & 45 & 19 \end{pmatrix}$ are inverses, find x , y and z .
- (b) Use the inverse above find x , y and z from $\begin{cases} ax - 9y + z = -7 \\ x + by + 2z = 3 \\ -5x - 6z = 2 \end{cases}$
- (c) Find x , y and z if $\begin{pmatrix} 2-x & 3+x \\ y+z & 0 \end{pmatrix} = \begin{pmatrix} y+1 & 4 \\ 1 & 0 \end{pmatrix}$

EXAMINATION TWENTY-TWO

1. (a) Evaluate $\frac{d}{dx} \left(\frac{\sin x}{\tan x} \right)_{x=\pi/6}$ put your answer in one decimal place
(b) Compute $\sqrt{\frac{9.67^3 \times \log(10.46)}{29.37 \times \ln(27.81)}}$ correct to 4 significant figures
(c) Find the value of x if $\sqrt[3]{3.12} = \log(7.091)$
(d) Estimate mean of: 89, 23, 56, 37, 86, 46, 23, 44
2. (a) Divide $f(x) = 3x^3 - 2x^2 + 10x - 50$ by $g(x) = x + 2$
(b) Draw the graph of $f(x) = \frac{x-1}{x}$

(c) Sketch the graph of $g(x) = \begin{cases} |x-3|-4 & \text{if } -1 < x < 7 \\ -|x-3|+4 & \text{if } -1 < x < 7 \end{cases}$

3. (a) The sum of first eleven terms of the series is 286, the second term is 7 find the common difference.

(b) Solve simultaneously $\begin{cases} x^2 + 2y^2 = 22.41 \\ xy = 6.3 \end{cases}$

- (c) Insert 4 terms between 3 and 14 so that the series become arithmetic.

4. (a) Differentiate $y = \sec^{-1} x$

- (b) Find the second derivative of $y = \sec(2x)$

(c) If $y = (\sin^{-1} x)^2$ show that $(1-x^2) \left(\frac{dy}{dx} \right)^2 = 4y$

5. (a) Find $\int \frac{dx}{2-3x}$

- (b) Compute the area between curves $f(x) = -x^2 + 3x + 4$ and $g(x) = 2x + 2$

- (c) Find the volume of the solid revolution formed when $f(x) = x - 2$ is rotated 360° about y -axis from $y = 2$ to $y = 6$.

6. (a) Given a frequency distribution table

Data	1 – 9	11 – 19	21 – 29	31 – 39	41 – 49
Frequency	5	13	17	10	X

- (i) Find X if the mean is 24.4

- (ii) Find variance to one decimal place.

- (b) Salt is packed in bags which the manufacturer claims contain 25kg each. Eighty bags were examined and the mass, x kg, of each is found. The results are $\sum(x-25) = 27.2$, $\sum(x-25)^2 = 85.1$. Find the mean and standard deviation of the masses.

7. (a) What is the probability of getting a 75% or better on a 8 question multiple choice test with 4 choices each, randomly guessing?

- (b) How many unique 6 letter words with or without meaning can be made from SOLITAIRE if letters may repeat as many times as possible?

- (c) Six people are to be chosen for a new committee from 8 males and 8 females. How many different ways can the committee be chosen if: -

- (i) There are no restrictions on who is chosen,

- (ii) There must be equal males and females on the committee

- (iii) The current chairperson must be re-elected to the committee?

- (iv) There must be at least 4 females on the committee

8. (a) Simplify $\sec^4 A - \sec^2 A$

(b) If $\tan A = \frac{3}{4}$ find $\tan 4A$

(c) Find the value of $\tan(75^\circ)$

(d) Find the equation connecting x and y from: $2A = \cos^{-1} x$, $A = \sec^{-1} y$

9. (a) Four years ago, the population of a certain village growing at a rate of 3% per year was 40,000 people, assume the rate of growth is the constant, find how many people were there 6 years ago?

(b) In a meantime, Tshs 3000 become 5500, if the rate of interest was 9% per annum compound interest, find the time invested.

10. (a) Sketch the graph of $f(x) = \begin{cases} \log_2(x^2 - 1) & \text{if } x > 1.5 \\ 3^x + 2 & \text{if } -3 < x < 0 \\ \frac{12 - 7x}{4} & \text{if } 0 < x < 1.5 \end{cases}$ and state the

domain and range of $f(x)$

(b) A manufacture produces nuts and bolts. It takes 1 hour of work on machine A and 3 hours on machine B to produce a package of nuts while it takes 3 hours on Machine A and 1 hour in machine B to produce a package of bolts. Machine He earns a profit of Tshs.1750 per package on nuts and Tshs.700 per package on bolt. How many packages of each should be produced each day to maximize his profit if each machine operates for at the most 12 hours a day?

EXAMINATION TWENTY-THREE

1. Use a non-programmable scientific calculator: -

(a) Evaluate $\left[\frac{\pi\sqrt{3} + \cosh(0.23)}{\sinh(0.86) + 3.2\sqrt{2}} \right]^{\sqrt{1.2}}$ into 6 significant figures.

(b) Given matrix Q; $Q = \begin{bmatrix} 8 & 7 & 1 \\ 2 & 0 & 5 \\ 7 & 8 & 3 \end{bmatrix}$ find

- (i) Determinant of matrix Q
- (ii) The transpose of matrix Q

(c) Given the table below

Data	31	40	56	67	78	89	99
Frequency	11	30	35	28	19	17	10

Calculate

- (i) Mean to 4 significant figures
- (ii) Standard deviation to 4 significant figures

2. (a) Sketch the graph of $x = \sqrt{\frac{y}{y-1}}$ and determine values of x and y

for which the relation is not defined

(b) Given $f(x) = \begin{cases} -2 & \text{if } x < -2 \\ 2 & \text{if } x > 2 \end{cases}$

- (i) Sketch the graph of $f(x)$
- (ii) State the domain and range of $f(x)$

3. (a) Solve for x and y from $\begin{cases} 3\sqrt{x} + 5\sqrt{y} = 13 \\ 7\sqrt{x} - 3\sqrt{y} = 1 \end{cases}$

(b) Find the next three terms of the series: 0, 1, 1, 2, 3, 5, 8, 13.

(c) The second, fourth and eighth terms of an arithmetic progression form three consecutive terms of a geometric progression. The sum of the third and fifth terms of an arithmetic progression is 20. Find: -

- (i) The common ratio
- (ii) The common difference
- (iii) The first term of geometric progression

4. (a) Differentiate $f(x) = 2x^2 + 3x$ by first principle of differentiation

(b) If $y = 2t^2 + 1$ and $x = t^3 + 2$ find $\frac{dy}{dx}$ in terms of t



(c) Air is leaking from a ball at the rate of 39cm^3 every minute, find the rate of change of the radius of the ball when $r = 10\text{cm}$

5. (a) Evaluate $\int \frac{x\sqrt{x}}{\sqrt{x+3}} dx$

(b) Find the area enclosed between the curve $y = x^2 + 1$ and $y = x + 2$ from $x = -2$ to $x = 2$

(c) Find the volume, V , generated when $y = \frac{1}{\sqrt{1+x^2}}$ is rotated about x -axis from $x = 0$ to $x = 1$, hence show that $4V = \pi$

6. (a) Given the following data below:

34 89 59 77 68 60 88 35 73
 47 39 73 53 49 70 36 17 26
 90

Find

- (i) Mean
- (ii) The quartiles
- (iii) The 60th percentile
- (iv) The 75th percentile

(b) In 2020 one hundred contestants show-up in one county for a change to be elected to contests for a parliamentary seat, their ages were as follows: -

Age (years)	36 – 40	41 – 45	46 – 50	51 – 55	56 – 60
No. of people	9	23	32	20	16

Calculate

- (i) Variance and standard deviation
- (ii) Draw an ogive
- (iii) Draw a histogram

7. (a) If $P(A \cap B') = 0.21$, $P(B) = 0.34$ and $P(A \text{ and } B) = 0.11$, represent this information on a Venn diagram. Find

- (i) $P(A' \cap B)$
- (ii) $P(A' \cap B')$
- (iii) $P(A' \cup B')$

(b) A bag contains red and yellow balls. The probability of drawing a red ball and then a yellow ball is 0.36. The probability of drawing a red ball first is 0.48. Find the probability of randomly choosing a yellow ball on the second draw, given that a red ball has already been drawn.

(c) What is the probability of getting a face card from an ordinary pack of playing cards?

8. (a) In a triangle ABC below,
 $BC = CA = y$ cm. If angle $ACP = \theta$
 and angle $BCP = 2\theta$, $AP = x$ and
 $PB = 1 - x$, prove that

$$\cos\theta = \frac{1-x}{2x}.$$

- (b) Express $4\cos X - 3\sin X$ into
 the form of $r\sin(X - \alpha)$

Hence find

- (i) The value of α
 (ii) The value of X from the $0^\circ \leq \theta \leq 360^\circ$

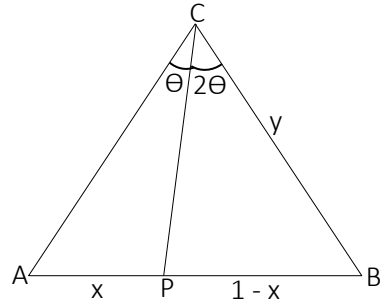

9. (a) If $\ln\left(1 - \frac{x}{100}\right)^7 = \frac{7}{9}$, show that $x = 100\left(1 - e^{1/9}\right)$

- (b) Tom invested Tshs 1,000,000/- in KCB bank, for 4 years at the rate of interest r compounded semi-annually. If at the end of the period Tom got an interest of Tshs 534,687/-, find the rate of interest.

10. (a) Solve by matrix (inverse) method
$$\begin{cases} \frac{1}{3}x + \frac{1}{4}y = 16 \\ \frac{1}{5}x - \frac{1}{8}y = 3 \end{cases}$$

- (b) Find the value of x if $\begin{pmatrix} 4 & x & 3 \\ 0 & -1 & 7 \\ 2 & 3 & 5 \end{pmatrix}$ is a singular matrix.

EXAMINATION TWENTY-FOUR

1. Use a non-programmable calculator to evaluate the following: -
 - (a) $\frac{\sqrt{3}\tan 60^\circ}{\cot 60^\circ} + \frac{\sqrt[4]{\log 15}}{3} \times (\cos 35^\circ - \sin 170^\circ)$ to three significant figures.
 - (b) $\frac{{}^{12}C_7 + {}^{13}P_{10} \times \sec^{-1}(2.1029)}{\sqrt{\tan^{-1}(1.2371)} \times \cos^{-1}(0.4755)}$ write the full answer
 - (c) From the list: 89, 57, 82, 45, 88, 76, 99, 83, 55, 85. Find
 - (i) $\sum x$
 - (ii) $\sum x^2$

2. (a) Given $h \circ f(x) = 4x + \ln x^2$ find $f(x)$ if $h(x) = 2x + 1$
- (b) Given $P(x) = x^3 - x^2 - 4x + 3$ and $Q(x) = x + 3$ find $P(x) \div Q(x)$
- (c) Sketch the graph of $y = \frac{1}{|x+2|}$ and state the domain and range

3. (a) Each year, a school manages to use only 60% as much paper as the previous year. In the year 2000, they used 700 000 sheets of paper.
 - (i) Find how much paper the school used in the years 2001 and 2002.
 - (ii) How much paper did the school use in total in the decade from 2000 to 2009?

- (b) Solve for x and y from
$$\begin{cases} \frac{1}{3x+y} + \frac{2}{3x-y} = \frac{3}{4} \\ \frac{1}{6x+2y} - \frac{1}{6x-2y} = -\frac{1}{8} \end{cases}$$
- (c) If y varies inversely as the square of $3/x$ and directly as the square root of z , when $y = 2$, $x = 3$ and $z = 0.25$, find x when $y = 4$ and $z = 0.49$.

4. (a) Differentiate $y = \tan\left(\frac{x+2}{x-1}\right)$
- (b) Find the third derivative of $f(x) = \sin^2 x$, hence show that
$$\frac{d^3 y}{dx^3} = -4 \frac{dy}{dx}$$
- (c) Differentiate $f(x) = \sin x + \cos\left(\frac{1}{2x}\right)$ with respect to $g(x) = e^{3x}$
- (d) Water is leaking from a cylindrical simtank at the rate of 12 cm^3 . If the diameter and height of the tank are equal.
 - (i) Calculate the rate of change of the radius when the radius is 2m.

(ii) Calculate the rate of change of the height of water in a tank height is 2.4m

5. (a) Evaluate the following integrals

(i) $\int \sec(2x) dx$

(ii) $\int_1^4 \left(\frac{x-1}{x+1} \right) dx$

(b) Find the area enclosed by the curves $y_1 = e^x$ and $y_2 = e^{2x}$ from $x = -2$ to $x = 3$.

(c) Find the volume generated when curves $y = x^2 - 4$ is rotated from $x = -2$ to $x = 2$.

6. (a) From the following frequency distribution table below; -

Data	1 – 5	6 – 10	11 – 15	16 – 20	21 – 25	26 – 30
Freq.	2	5	7	11	9	6

- (i) Calculate median
- (ii) Calculate Variance
- (iii) Calculate the 65th percentile.

(b) Given the numbers; -

78 94 77 67 83 73 84 46

Calculate

- (i) The difference between upper and lower quartiles
- (ii) The 40th percentile.

7. (a) Given that A, B and C are mutually exclusive events, such that: -

$P(A) = 0.23$, $P(B) = 0.14$ and $P(C) = 0.33$, find $P(A \cup B \cup C)$.

(b) The independent probabilities that student A, B and C will solve a

physics problem are $\frac{1}{3}$, $\frac{1}{7}$ and $\frac{3}{8}$ respectively. Calculate the

probability that: -

- (i) They all solved the problem.
- (ii) They all failed to solve the problem.
- (iii) Only one and among them solve the problem.

(c) In a class, 17 like bananas and 15 like strawberry. Two student likes neither and 8 students like both. A student is randomly selected from the class. What is the probability that the student likes bananas given that he or she likes strawberry?

8. (a) In a circle below O is the center of the circle, AB is a chord with the length of 15.3 cm and angle ACB is 50° .

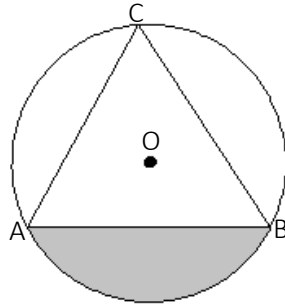

Calculate the shaded area correct to 2 decimal places.

- (b) Prove that

$$\frac{\sin A}{1 + \cos A} + \frac{1 + \cos A}{\sin A} = \frac{2}{\sin A}$$

- (c) If $x = 2 \cos A$ and $y = 3 \sin A$, show that $9x^2 + 4y^2 = 36$

9. (a) Evaluate the value of x : $3.2 = 1.01(1 - e^x)^3$ corrects to two decimal places.

- (b) An amount of money is invested at 8% for the first year, 11% for the second year, and 7% for the third year. What is the percentage increase in the value of the investment over this period?

- (c) A new bicycle was bought for Tshs 145,000/- at the beginning of 2009. Its value depreciates at 22.5% per annum.

(i) What will its value be at the end of 2012?

(ii) If inflation runs at 5.4% per annum during this time, what will be the replacement cost for a similar new bicycle then?

(iii) If the depreciated value is used as a deposit for the new car, what will be the balance to be paid?

10. (a) Sketch the graph of $\begin{cases} y + 1 \geq x, & y \leq x + 3 \\ x + y \leq 9, & x + y \geq 5 \end{cases}$ and hence maximize the

objective function, $f(x, y) = 3.8x + 4.6y$

- (b) If $A = \begin{pmatrix} 1 & 7 & 8 \\ 1 & 0 & 2 \\ -3 & -1 & 3 \end{pmatrix}$, calculate

(i) The adjoint matrix of A

(ii) The inverse of matrix A

- (iii) Use the inverse above to solve $\begin{cases} \frac{1}{3}x + \frac{1}{4}y - z = -3 \\ \frac{1}{5}x + \frac{4}{3}y + \frac{1}{7}z = 90 \\ \frac{1}{2}x - \frac{1}{5}y + \frac{1}{4}z = 10 \end{cases}$

EXAMINATION TWENTY-FIVE

1. Use a non-programmable calculator to evaluate

- (a) Evaluate $2.1 \left(\frac{1.892^2 + \sqrt{0.2718}}{\sqrt[3]{3.378} - \sqrt[5]{(-8.846)}} \right)^{2.1}$ correct to 5 decimal places.
- (b) From the table below, use a scientific calculator to answer the questions follows

X	12	23	32	43	50	59	65	78	84
Freq.	10	25	35	40	55	45	30	15	5

Calculate: -

- (i) Mean
 - (ii) Standard deviation corrects to three significant figures.
 - (iii) Variance corrects to three significant figures.
 - (iv) $\sum x^2 + (\sum x)^2$
2. (a) A function is defined as, $f(x) = \begin{cases} -2 & \text{if } x \leq -1 \\ |x-2| & \text{if } -1 < x \leq 3 \\ \frac{1}{5}(x^2+1) & \text{if } 3 < x \leq 5 \\ 5.2 & \text{if } x > 5 \end{cases}$
- (i) Sketch the graph of $f(x)$
 - (ii) State the domain and range of $f(x)$
 - (iii) Evaluate $f(-2) - 3f(2) + 2f(4) + 4f(10)$
- (b) A quadratic function is defined as $f(2)=8$, $f(-1)=3$ and $f(3)=13$
- (i) Find the function
 - (ii) Find the turning point of the function in (i) above
- (c) If $f(x)=ax+b$, $g(x)=2-x$ and $h(x)=\sqrt{x+2}$, show that the composite function is associative.
3. In a football show there are 200 seats. Ticket is sold at Kshs 5/- for an adult and Kshs 2.5/- for a child.
- (a) One evening, 80% of the seats in the room were occupied. If adults were 7 times numbers of children presents, calculate the total money collected from the sale of tickets.
 - (b) Another evening, x children were present and all the seat were occupied. The money taken for tickets was Kshs 905/-
 - (i) Write down an equation in x
 - (ii) Find the value of x.
 - (c) The money taken for tickets for a week is Kshs 10800/-. This sum is divided between costs, wages and profit in ratio 2:3:7. Calculate
 - (i) The profit for the week,

(ii) The compound interest earned if this profit is invested at a rate of 5% per annum for 4 years

4. (a) Use the first principle of differentiation to differentiate $f(x) = \frac{1}{x+1}$
- (b) At a given instant the radii of two concentric circles are 8cm and 12cm. The radius of the outer circle increases at a rate of 1cm/s and that of the inner increase at the rate of 2cm/s. Find the rate of change of the enclosed between the two concentric circles.
- (c) Find $\frac{dy}{dx}$ from $y = \frac{x^4}{x^3 - 4}$
- (d) Use small change concept calculate the value of $k = \sqrt{9.093}$ correct to 4 decimal places.
5. (a) (i) Evaluate $\int \frac{1}{\sqrt{x}(1+x)} dx$ (ii) Evaluate $\int_1^4 \ln(1+\sqrt{x}) dx$
- (b) Find the area of the surface generated by revolving the curve $y = x^3$, $1 \leq x \leq 2$.
- (c) Find the volume generated when $f(x) = \sqrt{x}(1-x^2)$ is revolved by x - axis for $1 \leq x \leq 2$.
6. (a) Given the table below
- | | | | | | | |
|-------|----|---|----|---|----|----|
| Data | -5 | 0 | 5 | 7 | 10 | 16 |
| Freq. | 2 | 7 | 11 | 9 | 6 | 3 |
- Calculate
- (i) Interquartile range
- (ii) Median
- (iii) Standard deviation
- (b) In a class of 50 students, the test scores were tabulated as follows: -
- 5 students scored between 0 and 15
 - 9 students scored between 15 and 30
 - 14 students scored between 30 and 45
 - 10 students scored between 45 and 60
 - 8 students scored between 60 and 75
 - 4 students scored between 75 and 90
- (i) Calculate the approximated median
- (ii) Calculate the approximated 75th percentile
- (iii) Calculate Variance using coding method
7. (a) Use the formula to evaluate ${}^4P_{20}$
- (b) In how many ways can seven children be arranged in a row so that two of them are always

- (i) Sitting together?
(ii) Not sitting together?
- (c) A dancing competition is attended by 25 group of people, best three dancers are to be given certificates as follows: The first winner gets a certificate and Tshs 10 million, the second winner gets a certificate and 7 million, while the third winner gets a certificate and 4 million. Assume that no group receives more than one prize, how many different ways can the first three winners be awarded?
8. (a) Prove that $\frac{\cos A}{1 - \sin A} - \frac{1}{\cos A} = \sqrt{-1 + \sec^2 A}$
(b) Find all value of Θ for which $\sin x + 2\cos x = 0$ from 0 to 2π
(c) In a triangle ABC, $AB = 4.3$ cm, $AC = 5.4$ cm and angle $BAC = 40^\circ$, find the length of BC
(d) Express $5\sin A - 12\cos A$ in the form of $R\sin(A - B)$ hence find R and B .
9. (a) Marabou invested Tshs. 38900 for a period of 8 years, he got Tshs 78379.80 at the end of the investment period, If the interest was compounded semi-annually what was the rate of interest?
(b) Inflation in a certain country is 15% per year. If this rate continues unchanged, after how many years will the cost of living have doubled?
10. Suppose a manufacturer of printed circuits has a stock of 200 resistors, 120 transistors and 150 capacitors and is required to produce two types of circuits.
- Type A: requires 20 resistors, 10 transistors and 10 capacitors
 - Type B: requires 10 resistors, 20 transistors and 30 capacitors
- If the profit on type A circuit is Tshs 5/- and that of type B is Tshs 12/-
- (a) How many of each circuit should be produced to maximize profit?
(b) What is the maximum profit?

EXAMINATION TWENTY-SIX

1. Use a non-programmable scientific calculator to evaluate each of the following: -

(a) $X = \left(\frac{3}{k\sqrt[3]{3p}} \right)^{\left[\frac{-(q+0.67)}{3q} \right]}$ where $k = 1.232$, $p = 34.22$ and $q = 0.838$

correct to 9 decimal places.

- (b) Given a frequency distribution table below

Data	10 – 20	20 – 30	30 – 40	40 – 50	50 – 60
Frequency	34	50	66	40	10

Calculate

- (i) Mean
- (ii) Standard deviation to 2 decimal places.
- (iii) Variance to 2 decimal places.
- (iv) $\sum x^2 - \sum x$

(c) Find the value of $\frac{5\frac{1}{5} + 3\frac{7}{9} - 2\frac{3}{7} - 3\frac{5}{8}}{6\frac{1}{7} - 2\frac{5}{8} + 1\frac{1}{9} - 11\frac{2}{5}}$ in 2 decimal places.

2. (a) Functions are defined as $f(x) = 2x + 1$ and $g(x) = \frac{x}{x+1}$

- (i) Sketch the graph of $f \circ g(x)$
- (ii) For what value(s) of x , if $f \circ g(x) = 4$

(b) State the domain and range of $h(x) = \sqrt{\frac{3}{x-4}}$

- (c) Given $p(x) = x^3 + 3x^2 - 4x + 1$, divide $p(x)$ by

- (i) $q(x) = 2x + 1$
- (ii) $r(x) = \frac{1}{3}x - 2$ and state the remainder for each case above.

3. (a) Given the series $\sum_{n=1}^n 25 \left(\frac{4}{5} \right)^n$

- (i) Write down the first three terms of the series
- (ii) The common ratio of the series
- (iii) The sum of the first 100 terms.

- (b) Grace and Gracious own pair of shoes in the ratio 5:6, Grace gains two more pairs and the ratio become 7:8, how many pair of shoes do each own initially?

- (c) A man deposited Tshs 5000 into an account of compound interest 8% per year, for how long will the man get Tshs 10,247/-?
4. (a) Find the slope of the tangent to the curve $8x^3 + xy^3 - 5y^2 = 2$ at $(1, -1)$.
- (b) Use the second derivative test to determine the nature of the stationary points of the curve $f(x) = 2x^3 + 3x^2 - 12x - 5$
- (c) Find the least value of $x^2 + y^2$ if $2x + y = 10$
- (d) Differentiate $y = \sin\left(\cos\left(\frac{x+1}{x-2}\right)\right)$
5. (a) Show that $\int_0^{\sqrt{a}} \left(\frac{x}{x^2 + a}\right) dx = \ln \sqrt{2}$
- (b) Find $\int \frac{\sin x}{1 + \cos x} dx$
- (c) Find the area enclosed between curves $y = x^2 + 2$ and $y = 10 - x^2$
6. In Kalembo Primary school 36 children were given a task to perform. The times taken in minutes, correct to nearest quarter were as follows: -
- | | | | | | | | | |
|----------------|----------------|----------------|----------------|----------------|----------------|----------------|----------------|----------------|
| $3\frac{1}{4}$ | 4 | 5 | $6\frac{1}{4}$ | 7 | 3 | 7 | $5\frac{1}{4}$ | $7\frac{1}{2}$ |
| $8\frac{3}{4}$ | $7\frac{1}{2}$ | $4\frac{1}{2}$ | $6\frac{1}{2}$ | $4\frac{1}{4}$ | 8 | $7\frac{1}{4}$ | $6\frac{3}{4}$ | $5\frac{3}{4}$ |
| $4\frac{3}{4}$ | $8\frac{1}{4}$ | 7 | $3\frac{1}{2}$ | $5\frac{1}{2}$ | $7\frac{3}{4}$ | $8\frac{1}{2}$ | $6\frac{1}{2}$ | 5 |
| $7\frac{1}{4}$ | $6\frac{3}{4}$ | $7\frac{3}{4}$ | $5\frac{3}{4}$ | 6 | $7\frac{3}{4}$ | $6\frac{1}{2}$ | $3\frac{3}{4}$ | 4. |
- (a) Prepare a frequency distribution table with class intervals starting from $3 - 3\frac{3}{4}$, $4 - 4\frac{3}{4}$, etc.
- (b) Calculate standard deviation correct to two decimal places.
- (c) Draw a histogram
- (d) Draw a cumulative frequency curve
7. (a) A family of four children. Assuming equal chances for boys and girls;
- Use a tree diagram to show all possible outcomes
 - Find the probability that there are three boys and one girl.
 - Find the probability that there are two boys and two girls.
- (b) How many odd numbers between 2000 and 4000 can be made using the digits 0, 1, 2, 3, 5, 7, 8 and 9?
- (c) How many possible choices of six questions are there in an examination paper of a total of 10 questions?

8. (a) Simplify $\frac{1}{\sqrt{x^2 - a^2}}$ if $x = a \sec \theta$
- (b) Prove that $\frac{\sin X}{1 + \cos X} + \frac{1 + \cos X}{\sin X} = 2 \operatorname{cosec} X$
- (c) If $x = \cos \alpha - \cos \beta$ and $y = \sin \alpha - \sin \beta$ express $x^2 - y^2 = \cos 2\alpha - \cos 2\beta$ in terms of x and y .
- (d) Evaluate $\tan(15^\circ)$
9. (a) Sketch the graph of $f(x) = \log(x - 1)$ and state the domain and range.
- (b) The amount (A) of the radioactive isotope Carbon-14 at any time t is given by the formula $A(t) = A_0 e^{kt}$ where A_0 is the initial amount of the element. If the half-life of the radioactive isotope Carbon-14 is about 5730 years;
- Express the amount of Carbon-14 left from the initial N milligrams as a function of time t in years.
 - What percentage of the origin amount of Carbon-14 left after 20,000 years?

10. (a) Prove that If $A = \begin{pmatrix} 2 & -1 & 6 \\ 0 & 9 & -2 \\ 2 & -3 & 9 \end{pmatrix}$ and $B = \begin{pmatrix} 1 & 1 & 1 \\ 2 & 1 & 3 \\ 0 & 2 & 1 \end{pmatrix}$ then

$$(AB)^T = B^T A^T .$$

(b) Solve by inverse of the matrix method $\begin{cases} \frac{2}{x} + \frac{3}{y} + \frac{10}{z} = 4 \\ \frac{4}{x} - \frac{6}{y} + \frac{5}{z} = 1 \\ \frac{6}{x} + \frac{9}{y} - \frac{15}{z} = 3 \end{cases}$

(c) Find solve for x and y : $\begin{cases} 3x + 5y = \begin{pmatrix} 3 & 41 \\ 19 & 3 \end{pmatrix} \\ 2x - 3y = \begin{pmatrix} 2 & -17 \\ 0 & -17 \end{pmatrix} \end{cases}$

EXAMINATION TWENTY-SEVEN

1. Use a non-programmable calculator to evaluate each of the following: -

(a) Evaluate $\frac{3+5\sqrt[3]{7.545}}{5-3\sqrt[5]{5.457}}$ correct to 4 significant figures.

(b) Evaluate $\sum_{n=2}^{n=4} \left(\frac{4!(n-3)}{n!} \right)^3$ correct to 4 decimal places.

(c) Calculate mean and standard deviation from the table below

Data	-23	-10	-6	5	13	25	33	45	56
Freq.	5	13	18	24	20	15	11	8	4

2. (a) If $f(x) = \frac{2x}{x-2}$ show that $f^{-1}(x) = f(x)$

(b) A function is defined as $f(x) = ax^2 + 4x + b$ if the maximum value of the function is 11 and $f(6) = 5$

(i) Find the possible values of a and b

(ii) The possible values of line of symmetry.

(c) Sketch the graph of $f(x) = x + \frac{1}{x+1}$ and state the domain and range of $f(x)$

3. (a) Find the sum of all odd numbers between 24 and 300.

(b) The sum of the digits of a two digits number is 9, if the digits are reversed the difference between the number obtained and the original number is 63, find the possible number.

(c) If the large number obtained in 3(b) above is the first term of a converging series, determine the sum to infinity of the series if the common ratio is $1/6$.

4. (a) The gradient of the tangent to the curve $y = 2x^3 + ax^2 - x + 3$ at $x = 2$ is 3, find the value of a .

(b) Find the second derivative of $f(x) = \frac{7\sqrt{x} - 4x}{\sqrt{x+1}}$

(c) A closed box case with a square base has a total surface area of 48 square meters. Find the maximum possible volume of the box.

5. (a) If $\frac{dy}{dx} = \frac{1}{(5x-3)^4}$, find $f(x)$ if $f^{-1}(0) = 1$

(b) Find the following (i) $\int 12\sin^2 x \, dx$ (ii) $\int (x+1)\ln(x+1) \, dx$

BAM

(c) Evaluate $\int_0^{\frac{\pi}{6}} \left(\frac{4}{\cot^2 \theta} \right) d\theta$ leave your answer in surd form.

6. (a) The 16 boys and 18 girls in a certain class were given a test. The mean mark for boys was 37 and the standard deviation of the boys was 7.1. The mean mark for the girls was 39 and the standard deviation of the girls was 5.2. Find the mean mark and standard deviation of the marks of the whole class.

(b) The end term one examination in basic applied mathematics examination obtained by 40 students in one of secondary school are as follows: -

66	87	79	74	84	72	81	78	68
74	80	71	91	62	77	86	87	72
80	77	76	83	75	71	83	67	94
64	82	78	77	67	76	82	78	88
66	79	74	64.					

(i) Prepare a frequency distribution table starting from 60 – 69, 70 – 79, etc.

(ii) Calculate mean by coding method.

(iii) Calculate standard deviation by assumed mean method.

7. (a) How many committees of 4 people can be selected from a group of 13 people?

(b) In how many ways can seven children be arranged in a row so that two of them are always

(i) Sitting together?

(ii) Not sitting together?

(c) TMA records indicates that in Arusha the probability that a day is dry is $\frac{2}{5}$. Simba F.C. is a football team whose record of success is better on dry days than in wet days. The probability that Simba F.C win on a dry day is $\frac{3}{7}$, whereas the probability that they win on a wet day is $\frac{4}{11}$. Simba football club are due to play their match in Arusha next Saturday.

(i) What is the probability that Simba will win?

(ii) Three Saturdays ago, Simba won their match. What is the probability that it was a dry day?

8. (a) Find $\tan(105^\circ)$ in the form of $x + y\sqrt{3}$ where x and y are integers.

(b) In $\triangle ABC$, $a = 12$ cm, angle A = 52° and angle B = 47° . Calculate the value of side b.

- (c) Prove that $\sin(A+B)\sin(A-B) = \sin^2 A - \sin^2 B$.
- (d) Solve for x from 0° to 360° inclusive from $\sec(3x) = 5$
9. (a) Find the value of x such that $3^{x+2} = 11^{2x-3}$
- (b) Sketch the graph of $P(t) = 10.3e^{\frac{5}{13}t}$, from the graph what is the value of P when $t = 2$?
- (c) A lorry got an accident while transporting radioactive waste, and the results in the area being contaminated by material with a half-life of 10 years. Experts suggested that the area should be quarantined until the radioactive material has reduced to 11% of its original level. How long are the experts recommending the quarantine should be in place for?
10. A retailer dealing with two brands of phone, Tecno phones and Samsung phones, he has 4 selling centers and he bought stock for his shops in different time duration as follows: -
- In one time, he bought a Tecno phone at USD 2/- and a Samsung phone at USD 3/- and he planned to use not more than USD 28 for shop A.
 - In the other time he bought a Tecno phone at USD 4/- and a Samsung phone at USD 1/- and he planned to use at most of USD 36/- for shop B.
 - The other time he bought a Tecno phone at USD 3/- and a Samsung phone at USD 5/- and he also planned to use not more than USD 21/- for shop C.
 - In a next purchase, he found that a Samsung phone costs USD 5/- and a Tecno phone costs USD 4/- he decided that he want to buy number of phones so that the cost difference between Samsung phones and Tecno phones he buys must not exceed USD 10/-
- (a) Formulate the linear programming problem
- (b) Draw the graphs of the constraints in (a) above
- (c) If the profit on a Tecno phone is USD 1.5/- and that of a Samsung phone is USD 1.8/- calculate how many phones should he sell to get a maximum profit?
- (d) What is the maximum profit?

1. (a) Use a scientific calculator

$$\sum_{n=2}^4 n \times (2^n - 3)^{1/n}$$

(a) Evaluate $\frac{\sum_{n=2}^4 n \times (2^n - 3)^{1/n}}{(4 - n)!}$ correct to 8 significant figures.

(b) Find the value of x from $9^{2x} - 7^{x+2} = 0$ correct to 3 decimal places.

(c) Find mean and variance from the frequency table below

Data	1 – 11	21 – 31	41 – 51	61 – 71	81 – 91
Freq.	19	30	55	43	13

2. (a) A function is defined as $f(x) = \begin{cases} x^2 & \text{when } -3 \leq x < 0 \\ -x^3 + 1 & \text{when } 0 < x \leq 2 \end{cases}$

(i) Sketch the graph of $f(x)$

(ii) State the domain and range of $f(x)$

(b) Given functions $h(x) = \begin{cases} x^2 - 1 & \text{if } 0 \leq x < 2 \\ 2x + 1 & \text{if } 2 \leq x < 4 \end{cases}$ and $g(x) = 5 - 3x$

(i) Find $h \circ g(x)$

(ii) Evaluate $h \circ g(0) + 3h \circ g(5)$

3. (a) Given the series $\frac{1}{2} + \frac{1}{12} + \frac{1}{30} + \frac{1}{56} + \frac{1}{90} + \dots$ find the next three terms.

(b) Given the series $1 + 2 + 3 + \dots + 499 + 500$. If 4 and multiples of 4 are removed from the series

(i) Find the number of terms of the resulting series.

(ii) Find the sum of the resulting series.

(c) Solve for x and y from $\begin{cases} 3x + 2y = 27 \\ x^2 - 4xy + 4y^2 = 9 \end{cases}$

(d) It is given that y is direct proportional to x and inversely proportional to z , if x is decreased by 10% and y increased by 30% what is the percentage change in z ?

4. (a) Find the derivative $y = \tan^{-1}(2x)$

(b) Determine the nature of the stationary point of the curve

$$f(x) = 1 + 4x^3 - 3x \text{ and sketch the graph of } f(x).$$

(c) Find $\frac{dy}{dx}$ if $x \cos(2y) - y^2 + 3x^2 = 5$

(d) A 3% error is made in measuring the diameter of the sphere. Find the corresponding percentage error in calculating; -

(i) The surface area of the sphere.

(ii) The volume of the sphere.

5. (a) Show that $\int_1^4 \frac{e^{\sqrt{x}}}{\sqrt{x}} dx = 2e(e-1)$
- (b) Find $\int \left(\frac{1 - \tan^2 x}{1 + \tan^2 x} \right)^2 dx$
- (c) Find the volume when $y = \frac{x}{\sqrt{x^2 + 1}}$ is rotated from $x = -1$ to $x = 1$
6. (a) Prove that $\frac{1}{n} \sum (x - \bar{x})^2 = \frac{1}{n} \sum x^2 - \bar{x}^2$
- (b) Calculate variance of these numbers:
12 23 10 20 11 15 12 10 20
- (c) Given the numbers:
10.0 12.0 10.1 13.0 13.2 13.7 x 10.2 10.3
If the standard deviation is 1.403 find the value of x to one decimal place.
7. (a) If $P(A) = 0.3$, $P(B') = 0.4$ and $P(A \cup B) = 0.72$, show if events A and B are:
(i) Mutual exclusive events
(ii) Independent events
(iii) Find $P(A|B)$
- (b) Given $P(A) = 0.24$, $P(B) = 0.13$, $P(C) = 0.31$ and $P(D) = 0.15$
(i) If A, B, C and D are mutual exclusive events find $P(A \cup B \cup C \cup D)$
(ii) If A, B, C and D are independent events find $P(A \cap B \cap C \cap D)$
- (c) A group of 5 people, is chosen from 8 men and 7 women. How many different ways can these people be selected if: -
(i) There are 3 men and 2 women?
(ii) There are at least 3 women?
(iii) There are at most 4 women?
8. (a) Eliminate P from $x = \cos P$ and $y = \tan 2P$
- (b) Prove that $\tan A = \sqrt{\frac{1 - \cos 2A}{1 + \cos 2A}}$
- (c) Show that $\tan^{-1}\left(\frac{1}{2}\right) + \tan^{-1}\left(\frac{1}{3}\right) = \frac{1}{4}\pi$
- (d) Solve for θ : $\cot \theta = \sqrt{3}$ from 0 to 2π
- (e) If $x = \cos \theta$ find y if $x^2 y - y(x^2 - 1) = 2x\sqrt{1 - x^2}$
9. (a) A radioactive isotope has a half-life of 20 days. Initially it has a mass of 60 grams. How much will there be after: -

(i) 20 days? (ii) 50 days? (iii) 100 days?

(b) Plot the graph of $y = e^{x^2-1}$

(c) DJ Murphy paid Tshs 22000/- for a new video unit. What would be the value of the units in 7 years if its rate of depreciation is 24% per annum?

10. (a) Given $D = \begin{vmatrix} b+c & c+a & a+b \\ c+a & a+b & b+c \\ a+b & b+c & c+a \end{vmatrix}$, If a, b and c are real numbers and

$D=0$ show that $a+b+c=0$ or $a=b=c$.

(b) Given constraints:
$$\begin{cases} x+3y \geq 68 \\ 4x+5y \geq 230 \\ 4x+y \geq 110 \\ 12x+7y \leq 840 \\ x \geq 0, y \geq 0 \end{cases}$$

(i) Sketch the graph of constraints above

(ii) Find the maximum and minimum of $f(x,y) = 5x + 2y$

	<i>Note</i>

EXAMINATION TWENTY-NINE

1. Use a scientific non-programmable calculator to evaluate the following mathematical expressions.

(a) Evaluate X from $\sin X = \frac{\sin(72^\circ)\tan(43^\circ) \times e^{-2} \times \sqrt[7]{5.34}}{(0.5623)^{-3} \times \ln(9.456) \times \cot(56^\circ)}$ correct to 3 decimal places.

- (b) Enter the following data in your calculator

Data	11	18	21	22	25	29
Freq.	18	23	33	20	16	10

Calculate

- (i) The mean
 - (ii) The variance
 - (iii) The sum of squares of x
 - (iv) The sum of x
2. (a) If $f(x) = \frac{2}{x+3}$ and $g(x) = \frac{x}{x-1}$ show that $f^{-1} \circ f(x) = x$
- (b) Sketch the graph of $f(x) = \begin{cases} x & \text{if } -3 < x \leq -2 \\ x+1 & \text{if } -2 < x \leq -1 \\ x+2 & \text{if } -1 < x \leq 0 \end{cases}$
- (c) Given the function $f(x) = \frac{2x-1}{x+2}$ and $g(x) = \frac{a}{2-x} + b$ find the values of a and b if $f^{-1}(x) = g(x)$
3. (a) Solve for x: correct to three decimal places from $4^x + 6^x = 9^x$
- (b) The sum of the two positive numbers is 5 times more than their differences, find these numbers if the difference between their squares is equal to 180.
- (c) Factorize completely $\frac{x^6 + a^2x^3y}{x^6 - a^4y^2}$
- (d) In a geometric progression, the product of the first and third terms is 144, the product of the second and fourth terms is 1296, if all terms are negative, find the terms.
4. (a) Differentiate $y = \frac{\sin(x+1)}{\tan(x+1)}$
- (b) A horse trough has triangular cross-section of height 25 cm and base 30 cm, and is 2m long. A horse is drinking steadily, and when the water level is 5 cm below the top it is being lowered at the rate of 1cm/min. Find the rate of consumption in litres per minute

- (c) If $y = \frac{2t}{1-t^2}$ and $x = \frac{t^2}{1+t}$ find $\frac{dy}{dx}$
- (d) Show that $(1+x^2)\frac{dy}{dx} = 2$ if $(1-x^2)\tan y = 2x$

5. (a) Find $\int \frac{1}{x^2-1} dx$

(b) Find the volume when $y = \frac{1}{\sqrt{x+2}}$ is rotated from $x = 2$ to $x = 3.5$

(c) Find the area enclosed by $y = \frac{2x}{x^2+1}$ from $x = 1$ to $x = 3$

6. (a) Iron rods were measured to nearest centimeter, as follows: -

12	13	14	10	11	13	18	29	13
15	12	19	12	13	18	12	13	17

Calculate

- (i) The mode
(ii) The Quartiles
(iii) The variance by coding method, Use $A = 14$

- (b) The tests scores of 100 students is summarized in the table below

Marks	16.5	21.5	26.5	31.5	36.5	41.5	46.5	51.5
Freq.	8	13	15	18	18	16	7	5

If the class intervals differ by 2 find the class intervals and hence calculate mode and variance of the data.

- (c) The frequency distribution in the table below show the distribution of 100 families according to their expenditure per week.

Expenditure	0 – 10	10 – 20	20 – 30	30 – 40	40 – 50
No. of families	14	25	X	20	15

Find the value of X, if the mode is $27\frac{3}{7}$ and the highest frequency is X.

7. (a) Find the value of n from ${}^n C_3 = 35$
- (b) A jar contains 73 marbles which are blue, red and green. There are twice as many red marbles as blue marbles, there are 19 more blue marbles than green marbles. Two marbles were drawn without replacement,
- (i) Calculate the probability that both marbles were of the same color
- (ii) Calculate the probability that the marbles were of different color

- (iii) Calculate the probability that no red marble drawn
8. (a) In a triangle ABC, AB = 4cm, BC = 6.5cm and AC = 9cm. Calculate the possible sizes of angle ABC correct to one decimal place.
- (b) Solve simultaneously:
$$\begin{cases} \sin(x+y) = \frac{1}{\sqrt{2}} \\ \cos 2x + \frac{1}{2} = 0 \end{cases}$$
 for values of x and y from 0° to 360° inclusive.
- (c) Plot the graph of $y = \cos(2x) - 2\sin(x)$ from -2π to 3π
9. (a) If $3x - y = 4$ find $\frac{8^x}{2^y}$
- (b) Solve for $\ln(3-2x) = \ln x + 2$ and leave your answer in form of e
- (c) In a bacteria colony, there are 200 bacteria initially. The colony is poisoned and bacteria are decreasing exponentially. After 10 hours there were 176 bacterial in a colony. After how long will the bacteria be 10 in a colony?

10. (a) Evaluate $\begin{pmatrix} 2 & 3 & 5 \\ 1 & 0 & 8 \end{pmatrix} \begin{pmatrix} 5 & 1 \\ 6 & 8 \\ 1 & 2 \end{pmatrix}$

(b) Solve by Cramer's rule:
$$\begin{cases} 2x + y - 3z = 30 \\ \frac{1}{3}x - \frac{6}{7}y + z = -15 \\ x - 2y - 2z = -38 \end{cases}$$

EXAMINATION THIRTY

1. Use a scientific non-programmable calculator to evaluate the following mathematical expressions.
 - (a) Evaluate $\frac{{}^{20}P_{13} + {}^{20}C_{17} \times \sqrt[5]{\ln(21.31)}}{{}^{15}C_{10} - {}^{15}P_{10} \times (3.121)^{0.3}}$ correct to 2 decimal places.
 - (b) Evaluate $\int_{0.43}^{1.54} ((2x+1)(x^3-3x))^{-10} dx$ correct to 8 decimal places
 - (c) Solve for x from $3(5^{2x}) - 22(5^x) + 7 = 0$ give your answer to 2 decimal places.

2. (a) A function is defined as $f(x) = \begin{cases} 1-2x & \text{if } -2 < x \leq 1 \\ -x^2 + 1 & \text{if } 1 < x \leq 2 \end{cases}$
 - (i) Draw a graph of $f(x)$
 - (ii) State the range of $f(x)$
 - (iii) If $g(x) = x - 1$ find $f \circ g(x)$
- (b) If $f(x) = -2x^3 + 6x^2$ on same xy-plane sketch the graph of $f(x+1)$ and $f(x-1)$. From the graph or otherwise, find the maximum and minimum values of both functions.

3. (a) In an arithmetic progression, If the tenth term is $2x + y$ and the seventh term is $x - y$: -
 - (i) Find the 100th term.
 - (ii) If the 100th term is 706 and the 19th term is 85, find the values of x and y .
 - (iii) Using the values of x and y obtained above, find the sum of the first 100 terms.
- (b) Tshs. 12000 is shared among 3 friends, Sarah, Baraka, and Carlos. If Sarah receives Tshs 2000 less than Baraka, and Baraka receives 3 times as much money as Carlos, how much each receive?
- (c) Convert 0.3636363636... into fraction using sum to infinity formula
- (d) Derive the formula for the sum of $8 + 88 + 888 + 8888 + \dots$. Hence find the sum of the first eight terms.

4. (a) Derive the first principle of differentiation and use it to differentiate $g(x) = \frac{1}{x^2}$
- (b) Eliminate A and B from $y = Ae^x + Be^{-2x}$
- (c) Find the stationary points of the curve $y = x^3 - 8x^2$

5. (a) Find y if $\frac{dy}{dx} = 3x + \frac{2}{x^2} - 3$ when $y(1) = 2$
- (b) Find the value of $\int_3^5 \ln(x-1) dx$ leave your answer with natural logarithms.
- (c) Find the volume when $y = x^2 - 1$ is revolved about x - axis from $x = -1$ to $x = 1$.
- (d) Given that $\frac{3x-7}{(x-3)(x+1)} \equiv \frac{A}{x-3} + \frac{B}{x+1}$ find the value of A and B ,
hence find $\int \frac{3x-7}{(x-3)(x+1)} dx$
6. (a) The heights of 80 female students are summarized by the equations $\sum (x-150) = 440$ and $\sum (x-150)^2 = 12100$, find the standard deviation of the 80 female students.
- (b) The amount of money, Tshs x , that 25 people had in their pockets are summarized by the equations $\sum (x-40) = -23$ and $\sum (x-40)^2 = 347$ find (i) $\sum x$ (ii) $\sum x^2$
- (c) The mean and the mode of the numbers:
 $x, x, y, y-2, y-1, 5, 9, 2, y-3$ and 3 are 5.5 and 5 respectively,
(i) Find the value of x and y .
(ii) Find the quartiles
(iii) Calculate variance.
7. (a) Mention 5 different places where probability is applied in real life
(b) World Health Organization encourages elderly people to have a flu vaccination each year. The vaccination reduces the likelihood of getting flu from 40% to 10% . If 45% of the elderly people visiting the center have the vaccination, find the probability that an elderly person chosen at random
(i) Gets flu.
(ii) Had the vaccination given that they get flu.
(iii) Had no vaccination given that they had no flu.
- (c) In how many ways can 11 people sit in a circular dining table for a meal, if two particular women refuse to sit together?
8. (a) Prove that $\frac{\cos(2X-Y) + \cos(2X+Y)}{\sin(X+Y) + \sin(X-Y)} = \frac{\cos 2X}{\sin X}$
- (b) Solve for x : $\tan(x-30^\circ) = \cos(x-30^\circ) + \frac{1}{\cos(x-30^\circ)}$ from 0° to 360° inclusive.

- (c) Plot the graph of $y = \sin(x) + \cos(2x)$ from -360° to 360° .
9. (a) Solve for x : $(\log_x 3)^2 + 3\log_x 3 - 4 = 0$
- (b) A company has an accounting policy that equipment is depreciated at 20% of the current value each financial year, and the initial value is set at the price paid for the equipment. The company buys equipment for Tshs 3,000,000 in 2002, and makes a further purchase in 2003 for Tshs 2,000,000. What was the value of the equipment in 2005?
10. (a) If $A = \begin{pmatrix} -2a & -3b \\ 3a & 5b \end{pmatrix}$ and $B = \begin{pmatrix} a & 3b \\ 4a & -2b \end{pmatrix}$ find matrix X such that $AX = B$
- (b) Students are about to take a test that contains questions of type A and B. Type A questions worth 10 points and type B worth 25 points. They must do at least 3 questions of type A but not more than 12. They must do at least 4 questions of type B but not more than 15. A student is required to answer at most 20 questions, how many of each type of questions must a student do to maximize the scores?

ADDITIONAL QUESTIONS

1. To estimate the height of the Eiffel tower above the level plain, Cathy measures the angle of elevation to the top of the tower and finds it to be 59° . Cathy moves 70 meters closer to the tower and measures the angle of elevation to the top of the tower and finds it to be 68° . Estimate the height of the Eiffel tower to two decimal places.

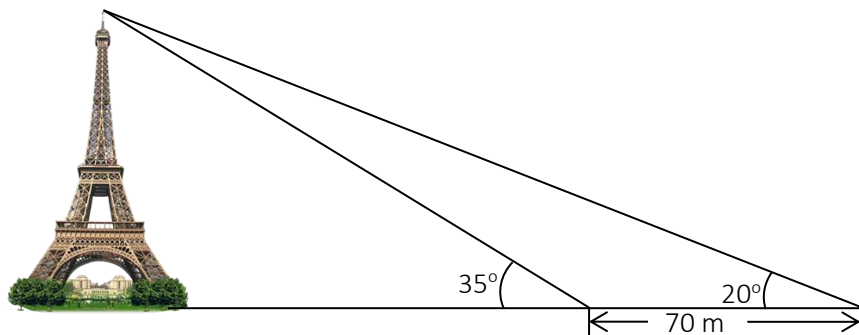

2. The cost of a small bottle of juice is $\$y$, the cost of a large bottle of juice is $\$(y+1)$. When Jade spends $\$36$ on small bottles only, she receives 25 more bottles than when she spends $\$36$ on large bottles only.
- Show that $25y^2 + 25y - 36 = 0$
 - Factorize $25y^2 + 25y - 36 = 0$
 - Solve the equation $25y^2 + 25y - 36 = 0$
 - Find the total cost of 1 small bottle of juice and 1 large bottle of juice.
3. (a) Pipes A can fill a tank of water in 5 hours, pipes B can fill the same tank in 8 hours and pipe C can empty the same tank in 7 hours. Alice opens all three pipes and she doesn't want the water to overflow, how long will it take for the tank to overflow?
- (b) Gagandeep bought a total of 20 game cards, some of which cost $\text{£}0.25$ each and some of which cost $\text{£}0.15$ each. If Gagandeep spent $\text{£}4.2$ to buy these cards, how many cards of each type did he buy?
- (c) The price of a computer including VAT is Tshs. 58,760/=. If 10% of VAT is removed from the original VAT, the price of a computer is discounted by 15%, the new price of a computer including new VAT becomes Tshs. 50061/=. Find the original price of a computer without VAT and the amount of original VAT?
4. (a) A water tank, having the shape of a rectangular prism of the base 100 square centimeters, is being filled at the rate of 1 liter per minute. Find the rate at which the height of water in the tank is increasing?

(b) Given that $f(2)=-1$, $f(-1)=3$, $f'(2)=5$ and $f'(-1)=-6$ while $g(2)=2$, $g'(3)=10$ and $g'(2)=7$ evaluate: -

(i) $(f \circ f)'(2)$ (ii) $(f \circ g)'(2)$ (iii) $(g \circ f)'(-1)$ (iv) $(g \circ g)'(2)$

(c) If $x = \frac{2at}{1+t^2}$ and $y = \frac{b-bt^2}{1+t^2}$, show that $\left(\frac{x}{a}\right)^2 + \left(\frac{y}{b}\right)^2 = 1$, hence or

otherwise find $\frac{dy}{dx}$.

(d) The graph of the functions $y=f(x)$ and $y=g(x)$ are given below. Suppose $h(x)=f(g(x))$ and $p(x)=g(f(x))$

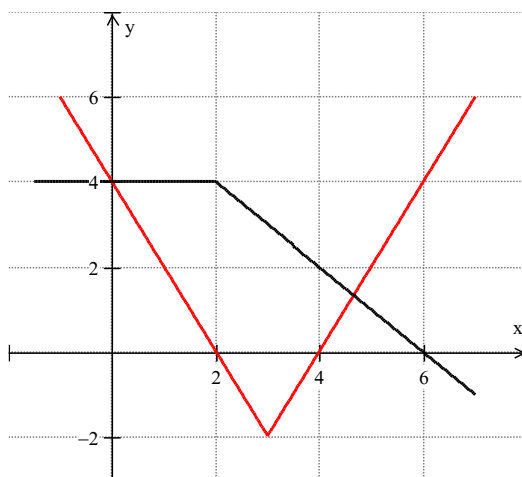

- (i) Find $h(4)$ and $p(4)$ are these values equal?
- (ii) Find $h'(4)$ and $p'(4)$ are these values equal?

5. (a) Perform the following (i) $\int \sqrt{\frac{x^2}{x+2}} dx$ (ii) $\int_{10}^{11} (x^{2/5} - 3x^{5/3} + 3) dx$

(b) Find the volume of the 3-dimensional shape formed when the function $y^2 = x^3(x^2 - 4)$ from $x = -2$ to $x = 0$

6. Think of a number, add three to it, multiply this result by 2, subtract 4, and then divide by 7. The last result is 2. What was the number you first thought of?
7. Bertha invested some money in a financial institution. The financial institution offered 6% per annum compound interest in the first two years and 8% in the third year. At the end of the second year, Bertha had Tshs. 1,820,232 in the financial institution. Determine the amount of money Bertha invested.



ANSWERS TO EXAMINATIONS

EXAMINATION ONE

1. (a) 3.466 (b) 0.0932 (c) -4.9168
 2. (a)

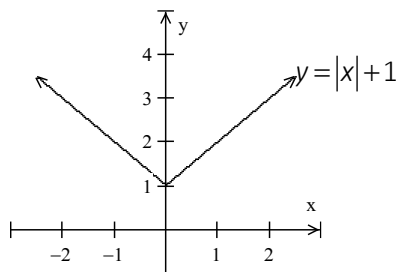

Domain = {x: x is a set of all real numbers}

Range = {y: y ≥ 1}

(b) $f \circ g(x) = \ln(e^{2x} + 2)$ and $g \circ f(x) = (x + 2)^2$

(c)

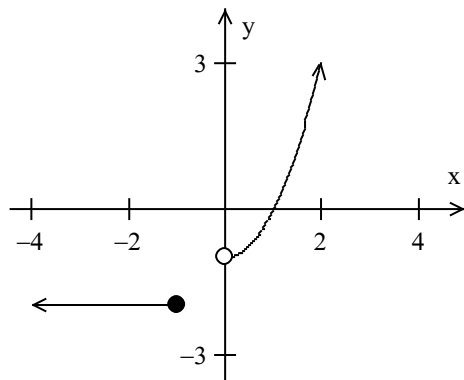

3. (a) (i) $A_1 = 84$, $A_{11} = 24$ (b) $\frac{313}{90}$ (c) $A_1 = -23$, $d = 0.75$

4. (b) $18(x+3)^3(2x-3)^4(x+1)$ (c) 2 cm/min

5. (a) $2\sqrt{x^2 - 3x} + A$ (b) 4 sq. units (c) 28.27 cubic units

6. (a) (i) Mean = 33.4 (ii) 2.63 (iii) An ogive

(b) $x = 1$.

7. (a) (i) 60 (ii) 288

(b) $1/2$

8. (a) -270° , -90° , 90° , 270°

(c) $(1-p)^2 q = 1-q$

9. (a) $f^{-1}(x) = \log \sqrt{x} + \frac{3}{2}$

and $g^{-1}(x) = 3^x + 2$

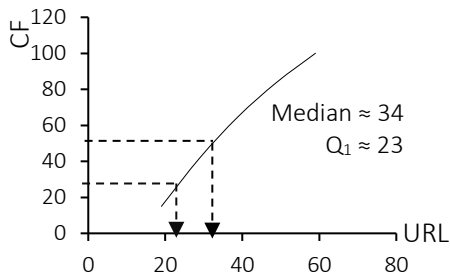

- (b) Vertical asymptote, $x = -4$
 (c) (i) 26.5% (ii) 556 (iii) 1905
 10. (a) Identity matrix
 (b) $x = 9, y = 0$ and $z = 1$.
 (c) The maximum is 9

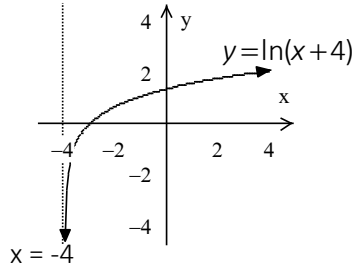

EXAMINATION TWO

1. (a) 8.9933 (b) 676 (c) Mean = 5.63, Variance = 3.99
 2. (a) (i) Vertical asymptote, $x = 1$, Horizontal asymptote, $y = 2$
 (ii) The x and y intercepts are $(-\frac{1}{2}, 0)$ and $(0, -1)$
 (iii) Graph
 (b) (i) Roots are $x = \{1, -2 \text{ and } 0.5\}$

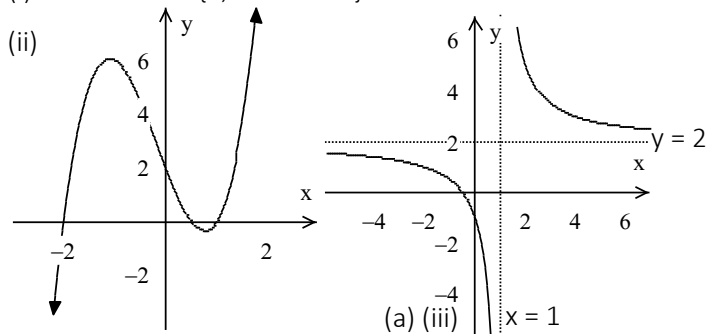

3. (a) The A.Ms are 8.7, 10.4, 12.1, 13.8, 15.5, the 100th term is 175.3. (b)
 (c) (i) $r = 7/3$ (ii) $A_4 = 9$
 4. (b) $90x(3x^3 - 1)^3(21x^3 - 1)$ (c) 1240
 5. (a) (i) $\frac{2}{3}x^{3/2} + 2\sqrt{x} + \frac{3}{2}x^2 - 2x + A$ (ii) 47/24
 (b) $y = t^2 - 3t + 3$ (c) (i) 24π (ii) $4\pi/9$
 6. (a) Frequency distribution table may be,

Class intervals	Frequency
30 – 40	4
50 – 60	10
70 – 80	14

90 – 100	25
110 – 120	15
130 – 140	11
150 – 160	9
170 – 180	7
190 – 200	5

- (b) 102.6 (c) 95.48 (d) 109.2
 7. (a) (i) $x=1/5$, $y=4/5$, $z=13/15$ and $p=1/6$ (ii) $52/75$ (b) 5040
 (c) 120960 ways

8. (b) 38.7° and 321.3° (c) $(1-x)^2 + (y-1)^2 = 1$

9. (a)

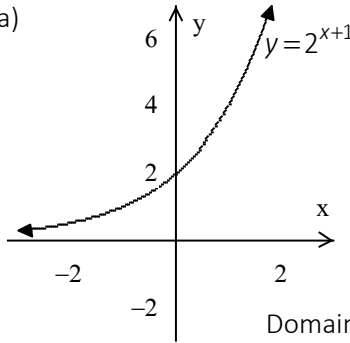

Domain = $\{x: x \text{ is a set of all real numbers}\}$
 Range = $\{y: y > 0\}$

- (b) Tshs. 329832/- (c) (i) They are asymptotic to x – axis (ii) Pass through point $(0, f(0))$
 10. (a) $x = 3$ and $y = -3$
 (b) He should use 7 acres for maize and 3 acres for wheat, the minimum cost is Tshs. 345,000/-

EXAMINATION THREE

1. (a) 4.79332 (b) (i) 0.602 (ii) 0.153 (c) $x = 1.114$ or $x = 4.072 \times 10^{-5}$
 2. (a) (i) $f \circ g(x) = 6x^2 + 8$ (ii) $g \circ f(x) = 36x^2 + 24x + 5$

(b) (i)

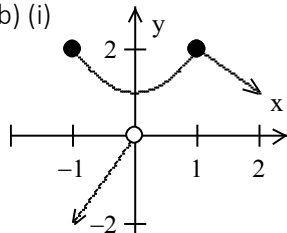

(ii) Domain = $\{x: x \in R\}$

Range = $\{y: y \leq 2\}$

(iii) 12.27

3. (a) $x = 39$ and $y = 4$ (b) $x = 2$, $y = 1$ and $z = 3$ or $x = -4$, $y = -5$ and $z = 9$.

4. (b) $\frac{dy}{dx} = x^x(\ln x + 1)$ (c) $\frac{dV}{dt} = 33.32\pi \text{ cm}^3/\text{s}$.
5. (a) (i) $\frac{1}{3}x(x-2)\sqrt{x^2-2x} + A$ (ii) $\ln\sqrt{2}$ (b) 2 sq. units (c) 367.8π c. units.
6. (a) (i) SIQR = 21.75 (ii) $P_{45} = 50.5$ (b) (i) $Q_1 = 29.83$ (ii) Mean = 41.1
7. (a) (i) $1/3$ (ii) $2/3$ (b) $n = 9$ (c) (i) 2827440 ways (ii) 0.094
8. (a) $72.8^\circ, 90^\circ, 114.93^\circ, 245.07^\circ, 270^\circ, 287.2^\circ$.
 (c) (i) $B = 74.62^\circ, C = 65.38^\circ$ (ii) $AB = 5.66 \text{ cm}$ (iii) 10.9 sq. cm
9. (a)

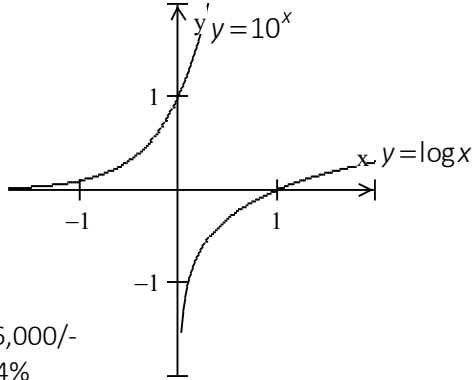

- (b) (i) 46,000/-
 (ii) 24%
 (iii) 5120/-

10. (a) (i) $\text{Det}(A) = 175$

(ii) Ad joint (A) =
$$\begin{pmatrix} -23 & 29 & 11 \\ -10 & 5 & 20 \\ 97 & -31 & -54 \end{pmatrix}$$

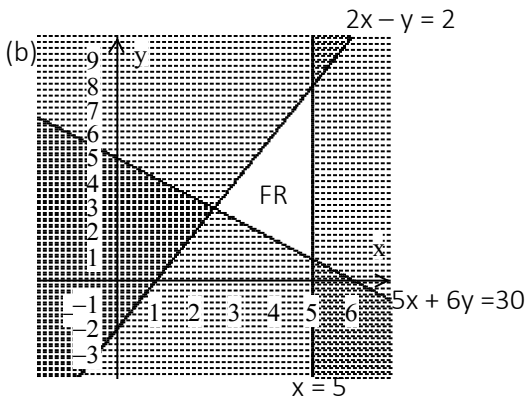

EXAMINATION FOUR

1. (a) (i) 1.257 (ii) 903.425 (b) $y = 1.2528$ or 0.9808 (c) 0.5218

2. (a) $f(x) = x^4 + x^3 - x + 3$ (b)

Domain = $\{x : x \neq 1\}$ and

Range = $\{y : y \neq -1\}$

(c) Is not a function

Reason:

- Domain has more than one value of range

E.g. when $x = 9$

Then $y = -3$ or 3

- Using a graph the vertical line crosses the curve twice, therefore, the vertical line test proves that it is not a function.

Domain = $\{x : x \geq 4.5\}$ and Range = $\{y : y \in R\}$

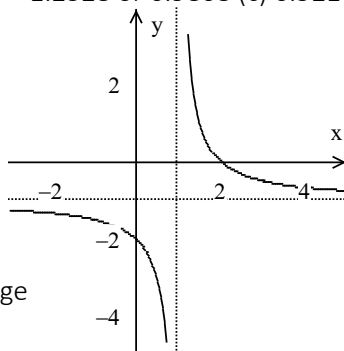

3. (a) Alfred = 24/-, Benjamin = 76/-

(b) $A_1 = 13$ and $d = 6$

(c) 48 days.

4. (a) Maximum $(-1, 4)$, minimum $(1, 0)$

(b)
$$\frac{dy}{dx} = \frac{4-x}{(x^2+2)^{3/2}}$$

(c) (i) 0.382 cm/s

(ii) 0.382 cm/s

(iii) 2.4 cm²/s

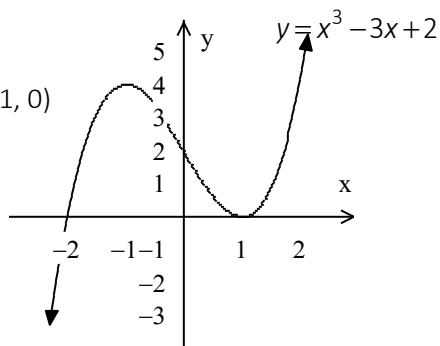

5. (a) $\ln(e^x - 2) + A$ (b) $-\frac{x}{x^2+1} + A$ (c) 0.67 sq. units.

6. (a) (i) 40.19 (ii) 20.90 (iii) 31.58 (b) Quartiles, Deciles and Percentiles.

7. (a) (i) 0.3618 (ii) 0.4996 (b) A. (i) 0.0361 (ii) 0.9639
B. (i) 0.0256 (ii) 0.3456

8. (b) $a = 2, b = 1$ and $c = 1$ (c) $0^\circ, 60^\circ, 300^\circ, 360^\circ$.

9. (a) (i) Tshs. 5387 (ii) Tshs. 1387 (c) 181576

10. (b) Machine A should be run for 7 hours and Machine B for 3 hours. The minimum cost is Tshs. 21500/-

EXAMINATION FIVE

1. (a) 1.67923 (b) (i) $\begin{pmatrix} 8 & 1 \\ 2 & 3 \end{pmatrix}$ (ii) 22
2. (a) (i) $g \circ h(x) = 3x^2 - 9x + 4$ (ii) $h \circ g(x) = 9x^2 + 15x + 4$
 (b) Domain = $\{x : x > 3/2\}$, Range = $\{y : y \in R\}$ Asymptote $x = 3/2$
 (c) Domain = $\{x : x \neq -\frac{29}{6}\}$
3. (a) (i) 26,700 (ii) 70,800 (iii) 0 (b) (i) 20, 164 (ii) Neither A.P nor G.P (c) 1
4. (a) $\frac{dg}{dx} = 4x^3 - 12x^2 + 6x - 12$ (b) $\frac{dy}{dx} = \frac{7}{(x+3)^2}$ (c) 1.3 units per second.
5. (a) $\frac{2}{15} \sqrt{x}(6x^2 + 10x + 15) + A$ (b) $y = 1 + x^2 - x^3$
 (c) $y = 2x^2 - \ln x - x - 1$
6. (a) 47.2 (b) 50 (c) 53.04 (d) 20.85
7. (a) (i) 0.1792 (ii) 0.1686 (iii) 0.2028 (b) 0.7334 (c) 245700 ways.
8. (a) Required to prove sine rule: $\frac{a}{\sin A} = \frac{b}{\sin B} = \frac{c}{\sin C}$
 (b) We are required to use sine rule to prove Pythagoras theorem
 Prove, Let $C = 90^\circ$ thus $B = 90^\circ - A$
 Thus $b \sin A = a \sin B \Rightarrow b \sin A = a \sin(90^\circ - A)$ but $\sin(90^\circ - A) = \cos A$
 Thus $b \sin A = a \cos A$ also from sine rule, $a \sin C = c \sin A$ and
 $b \sin C = c \sin B$ but also $\sin(90^\circ - A) = \cos A$, thus $b \sin C = c \cos A$

$$\begin{cases} b \sin A = a \cos A \\ a \sin C = c \sin A \\ b \sin C = c \cos A \end{cases}$$
 We have $\begin{cases} b \sin A = a \cos A \\ a \sin C = c \sin A \\ b \sin C = c \cos A \end{cases}$ thus
 Consider the last two equations
 $(a \sin C)^2 + (b \sin C)^2 = (c \sin A)^2 + (c \cos A)^2$
 $a^2 \sin^2 C + b^2 \sin^2 C = c^2 (\sin^2 A + \cos^2 A)$ from $\sin^2 A + \cos^2 A = 1$
 $(a^2 + b^2) \sin^2 C = c^2$ but $\sin C = 1$ because $C = 90^\circ$,
 $a^2 + b^2 = c^2$ hence proved,
 (c) $A = 40.6^\circ$, $B = 83.7^\circ$ and $C = 55.7^\circ$
9. (b) $x = 2$ (c) Inverse, $f^{-1}(x) = \sqrt{5^x - 3}$, Domain = $\{x : x \geq \ln 3 / \ln 5\}$
10. (a) 1 and 2 units of A and B respectively (c) $p = 10$ and $q = -5$

BAM

EXAMINATION SIX

1. (a) 3.5 (b) 0.852 (c) Mean = 6.35, Std. dev. = 2.14, Var. = 4.59
 2. (a)

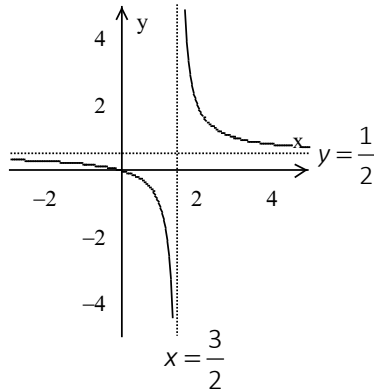

Domain = $\{x : x \neq 1.5\}$

Range = $\{y : y \neq 0.5\}$

(b) $f(x) = x^3 + \frac{16}{3}x^2 + 3x + 2$

3. (a) $r = 5/7, a = 12/7$ (b) (i) $y = \frac{11}{12}z^2\sqrt{x}$ (ii) $x = 576$ (c) $x = 0, x = 1.43$.

4. (b) $\frac{dy}{dx} = \frac{18(x^2 + y^2)^2 x - 4x}{3y^2 - 18y(x^2 + y^2)^2}$ (c) 0.398 m/h

5. (a) $\ln\sqrt{e^{x^2} + 3} + A$ (c) 10.7 sq. units

6. (a) 48 (b) 52.17 (c) 53.4

7. (a) (i) 0.3 (ii) 0.52
 (b) (i) 0.1 (ii) 0.47 (iii) 0.37
 (c) 13,800 ways

8. (b) $45^\circ, 90^\circ, 270^\circ, 360^\circ$
 (c) $-48.2^\circ, -311.8^\circ, 48.2^\circ$ and 311.8° .

9. (a)

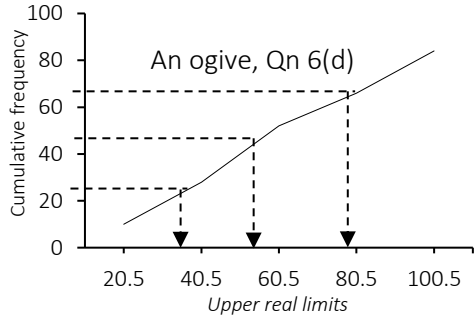
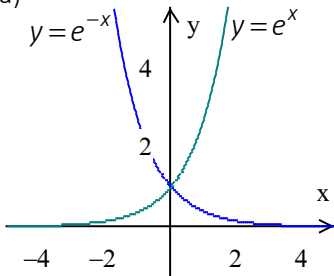

$Q_1 \approx 33, Q_2 \approx 52$ and $Q_3 \approx 76$

9. (b) Tshs. 175,276/=

9. (c) Tshs. 1,366,838.30/=

10. (a) (i) **Feasible region:** The unshaded region of a linear programming graph

- (ii) **Bounded feasible region:** Is a feasible region which is between the lines of the inequalities

- (iii) **Optimal solution:** Is a point of the feasible region which gives an optimal value.
- (b) For wheat should be 80 hectares and for barley should be 88 hectares, the maximum profit is Tshs. 11240/=

EXAMINATION SEVEN

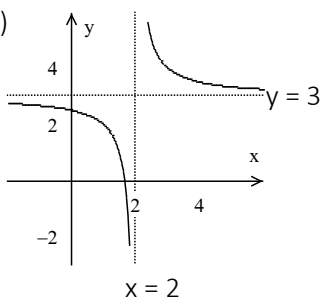
- (a) 0.629051 (b) 2.686036
- (a) (i) $f(g) = 2e^{3x} - 5$ (ii) $g \circ f(x) = e^{-15}$ (b) 
- (a) 132.125 (b) 7/10
(c) (i) $6 + 10 + 14 +$
(ii) Arithmetic series, $S_{11} = 4202$
- (a) $f'(x) = 2e^{2x}$ (b) Min. point (2, -16)
Max. point (-4, 92)
(c) $MC(x) = 200 - 0.6x$, $MC(100) = 140$
(d) 70.44 km/h
- (a) (i) $\sqrt{19} - \sqrt{7}$ (ii) $\frac{1}{22}(2x-3)^{11} + A$ (b) 4.5 sq. units
- (a) (i) $Q_3 = 26$, $P_{40} = 15.4$ (b) (i) 28.07 (ii) 29.5 (iii) Var. = 482.42
- (a) Independent (b) 20160 ways (c) 360 words
- (a) $\tan(15^\circ) = \frac{1 + \sqrt{3}}{1 - \sqrt{3}}$ (b) $-60^\circ, -330^\circ$, (c) (i) 7.7m (ii) 21.05 m (iii) 11.89°
- (a) 29.44%
- (b) $x = 20$, $y = 20$, $z = 0$ (b) 160 hectares, 60 for tomatoes and 100 for potatoes.

EXAMINATION EIGHT

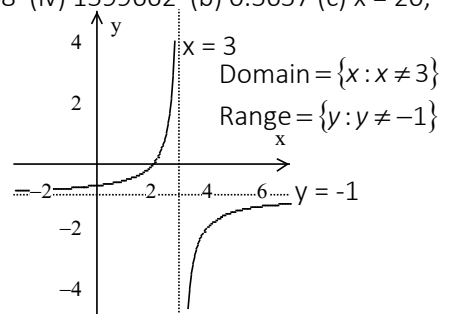
- (a) (i) 60 (ii) 12.7451 (iii) 25648 (iv) 1599662 (b) 0.5657 (c) $x = 20$, $y = 50$ and $z = 30$.
- (a) $g(x) = \frac{x}{2x-1}$ (b) 
- (a) (i) $A_1 = 10$
(ii) $d = -4$
(b) 116/495
(c) $r = 6$
- (b) The max. point is (1, 1), inflexion point is (0, 0) (c) 4cm/s

5. (a) $\frac{1}{15}(2x-1)^{3/2}\sqrt{3x+1} + A$ (b) $a = 6$ (c) 21.21 cubic units
6. (a) (i) Med = 6.4 (ii) SIQR = 1.65 (b) (i) 54.7 (ii) 54.26 (iii) 46.77 (iv) 13.563
7. (a) (i) 124750 (ii) 30 (b) (i) 0.2 (ii) Not independent (iii) 0.4 (c) 75600
8. (a) -138, -46, 46 and 138 (b) $\cot A, 30^\circ$ (c) $x^2 + y^2 = 1$
9. (b) (i) $YX = \begin{pmatrix} -13 & -1 \\ 55 & 7 \\ 48 & 4 \end{pmatrix}$ (ii) XY is not possible, rows and column mismatch.
- (c) $b = -1, y = 1$ and $z = 2$
10. (a) (i) An objective function is a function of several variables subjected to a certain condition.
(ii) A bounded feasible region is a feasible region which is enclosed by constraints and or axes in all sides.
(iii) The non-negativity constraints restrict the feasible region to be in the first quadrants so that no negative values shall be obtained.
(b) The company should produce 100 non programmable calculators and 170 programmable calculators to maximize profit.

EXAMINATION NINE

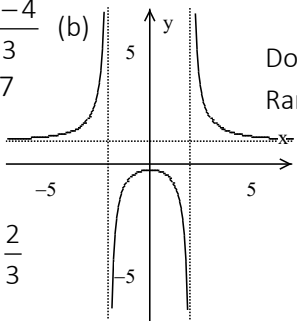
1. (a) 0.0307 (b) (i) $e^3 \times \ln(4) + \sqrt[3]{7} + 3!$ (ii) $\left(\frac{4}{7}\right)^6 + \left(\frac{3}{5}\right)^8 + 9^4$
2. (a) $f^{-1}(x) = \sqrt{\frac{x-4}{3}}$ (b)  Domain = $\{x: x \neq 2 \text{ and } x \neq -2\}$
Range = $\{y: y \neq 1\}$
- (c) $f(x) = 5x + 7$
3. (a) -15250
(b) 28
(c) $r = 2$ or $r = -\frac{2}{3}$
4. (a) $f'(x) = -1$
(b) $\frac{dy}{dx} = \frac{4x^3y + 9x^2}{5y^4 - x^4}$ $x = -2$ $x = 2$
(c) Min. point $\left(\frac{2}{3}, -\frac{4}{9}\right)$, Max. point (0, 0)
5. (a) $x - 10\ln(x+7) + A$ (b) 254.75 (c) 0.25 sq. units (d) 14.14 c. units
6. (a) (i) 28.15 (ii) 27.3 (iii) 36.57 (iv)

- (b) (i) 2.25 (ii) 16.5
7. (a) (i) 0.42 (ii) 0.3768
 (b) 40 (c) 12,441,600
 (c) 12,441,600
 (d) $825/64883$
8. (a) (i) $24/25$ (ii) $7/25$
 (c) 60^0
9. (a) $a=5$ (b) $x=5, y=7$ and $z=10$
10. (a) Graph

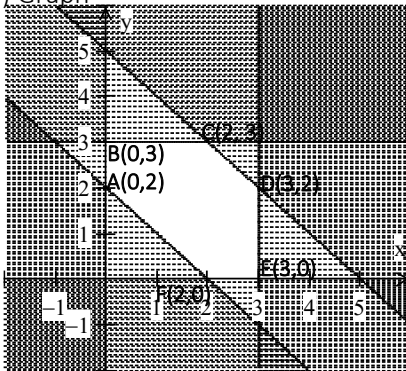
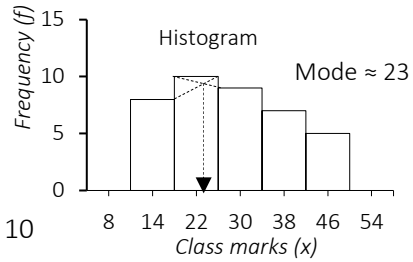

Corner point	$f(x, y) = 2x + 3y$
A(0, 2)	6
B(0, 3)	9
C(2, 3)	13
D(3, 2)	12
E(3, 0)	6
F(2, 0)	4

The intermediate values are 6, 9, 12

(b) Constraints

Let x be number of PCs sold and y be number of laptops sold per month.

$$\text{Thus } \begin{cases} 2x + 3y \geq 168 \\ x \geq 15, x \leq 80, 2y \geq x \\ x \geq 0, y \geq 0 \end{cases}$$

He must sell 80 PCs and 40 laptops

EXAMINATION TEN

1. (a) 0.1023 (b) $x=5, y=-10$ and $z=15$ (c) -0.5693
2. (a) Graph

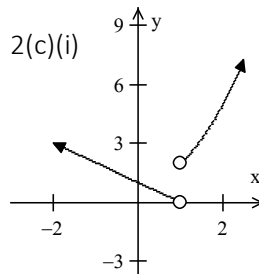
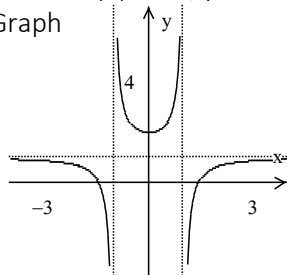

- (c) (ii) Domain = $\{x: x \text{ is a set of all real numbers except } 1\}$
 Range = $\{y: y > 0\}$

3. (b) 4 (c) 3 and 75 (d) $x = -2, y = -10$ or $x = 8, y = 50$.

4. (a) $\frac{dy}{dx} = -\frac{4x}{(x^2+1)^2}$ (c) 25 sq. units

5. (a) $\ln(x + \sqrt{x^2 - 5}) + A$ (b) 0.75 (c) 1.2π cubic units

6. (a) (i) $X = 33$ and $Y = 62$ (ii) 40
 (b) (i) 2.5 (ii) 10
 (iii) 13.5 (iv) 7

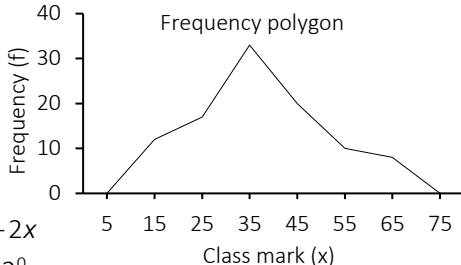

7. (a) 362880
 (b) (i) 0.39 (ii) 0.51
 (iii) 0.51

8. (a) $(y+3)(x-1)(x-3) = 4 - 2x$
 (b) $\pm 54.7^\circ, \pm 125.3^\circ$ (c) 48.2°

9. (a) (i) 5 (ii) 11 (iii) 83.3 minutes (b) $a = 2, b = 3$ and $c = -2$

10. (b) $a = 0$ or $a = \pm 1$

EXAMINATION ELEVEN

1. (a) -0.817 (b) 32.428 (c) -172

2. (a) (i)

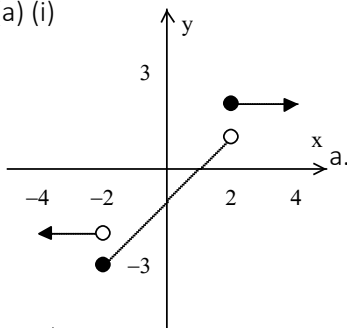

(ii) Domain = $\{x: x \text{ is a set of all real numbers}\}$

Range = $\{y: -3 \leq y \leq 1 \text{ and } y = 2\}$

1.

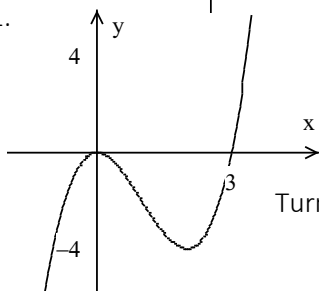

Turning points are $(0, 0)$ and $(2, -4)$

3. (a) $x = 4$ and $y = 9$ (b) $x = 5/3$ or $x = 1/3$ (c) (i) $x < 0$ (ii) $x = -3$.

4. (a) $\frac{4x\sqrt{x+1}-1}{4\sqrt{x^2-\sqrt{x+1}}\sqrt{x+1}}$ (c) 2.022

5. (a) (i) $\ln(3 + \sin x) + A$ (ii) $x - \tan^{-1} x + A$ (c) 20.83 sq. units.

6. (a) Frequency distribution table

Class Intervals	Frequency (f)
20 – 29	3
30 – 39	14
40 – 49	8
50 – 59	6
60 – 69	7
70 – 79	8
80 – 89	4
90 – 99	4

(b) (i) 52.83 (ii) 35.97 (iii) 424.69

7. (a) $1/495$ (b) $2/3$ (c) 5040

8. (a) $\cos 2A$ (b) 20.91° , 69.09° , 200.91° and 249.09°

9. (a) (i) 103,088 (ii) 2 years, and 8 months

(b)

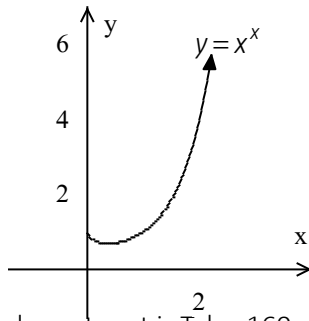

6 (c) $\frac{y \ln 6}{2\sqrt{x-1}}$

10. The lowest cost is Tshs. 160 million

EXAMINATION TWELVE

1. (a) 9.1345 (b) 14.34 (c) 2.7921

$$2. (a) (i) f(x) = \begin{cases} \frac{1}{2}(x+5) & \text{if } x > 1 \\ 1 & \text{if } -1 < x \leq 1 \\ x-1 & \text{if } x \leq -1 \end{cases}$$

(ii) Domain = {x: x is a set of all real numbers}

Range = {y: y = 1, y ≤ -2 and y > 3}

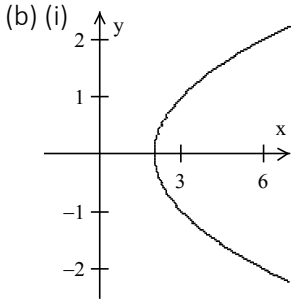

(ii) Domain = {x: x ≥ 2}

Range = {y: y all real numbers}

3. (a) (ii) $d = -2$, $A_n = 22 - 2n$ (b) $a = -\frac{7}{50}$ and $b = \frac{53}{50}$

4. (a) $\frac{dy}{dx} = \frac{\cos x}{2y-1}$ (b) 3.1544 (c) $x = 15\sqrt{10}$ and $y = 10\sqrt{10}$

5. (a) $\frac{3^{2x}}{\ln 9} + A$ (b) $\frac{1}{3}\ln(x^2 + x + 1) + \frac{1}{3}\ln(x-1) + \ln x + A$ (c) 13.5 sq. units

6. (a) (i) Frequency distribution table

Data	20 – 33	34 – 47	48 – 61	62 – 75	76 – 89
Frequency	9	16	14	6	5

(ii) 47.5 (iii) 49.46 (iv) 44.4

7. (a) (i) 1680 (ii) 4096

(b) (i) Event: A required subset of a sample space;

(ii) Sample space: all possible outcome of a random experiment.

(c) (i) 0.018 (ii) 0.19 (iii) 0.027 (iv) 0.0026

8. (a) (i) $X = 106.1$ m, $Y = 238.0$ m (b) $\pm 70.5^0$, $\pm 289.5^0$

9. (a) Domain = {x: x < 2} and Range = {y: y ∈ R} (c) (i) 33% (ii) 2.07 yrs

10. (b) $k = 12/7$ (c) $x = 1$

EXAMINATION THIRTEEN

1. (a) 2.0048 (b) (i) 5.48 (ii) 2.11 (iii) 87.75

2. (a)

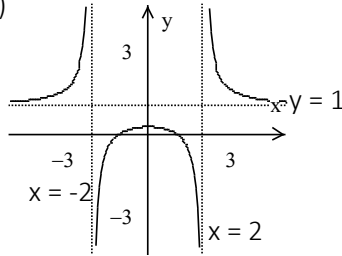

Domain = $\{x: x \neq \pm 2\}$

Range = $\{y: y \neq 1\}$

(b) $f(x) = x^2 - 4x + 3$, y-intercept, $y = 3$.

(c)

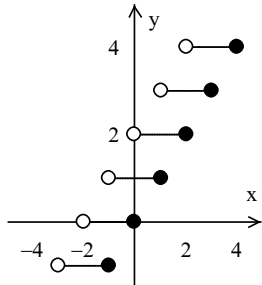

3. (a) $x = 3$ and $y = 1$ or $x = 2$ and $y = -1$ (b) (i) $A_1 = -2.5$ and $d = 0.5$
(ii) $n > 95$ (c) 13, 34, 89 and 144.

4. (a) $f'(x) = 8x + 2\sin(2x)$ (c) $x = 2$

5. (a) 526.5 (b) $k = 60.08$, 30.01m/s

6. (a) (i) Mean = 60.3 (ii) Variance = 220.36 (b)

7. (a) (i) 3,628,800 (ii) 240

(b) (i) $\frac{1}{12}$ (ii) $\frac{1}{72}$ (iii) $\frac{1}{9}$

8. (b) Angle A = 44.05° ,

Area = 6.953 cm^2

9. (a) $\frac{d^2y}{dx^2} = -\frac{3x^2 + 4x + 2}{(x^2 + x)^2}$

(b)

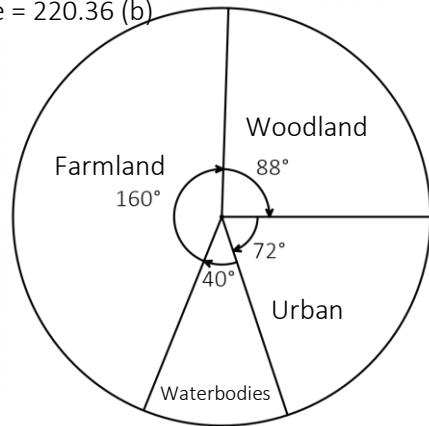
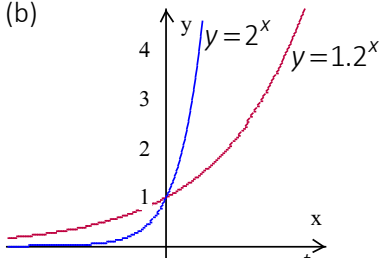

Pie chart Qn 6

2-9 (i-6V(i-3=55003)0(0635)9 (ii) Tshs. 425579.50

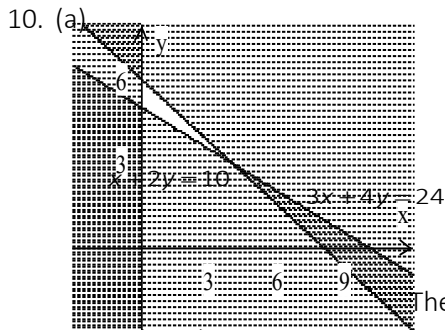

The minimum value is 2300

(b) $C = \begin{pmatrix} 2 & 0 \\ 1 & 3 \end{pmatrix}$

EXAMINATION FOURTEEN

1. (a) 1.923 (b) 0.1362 (c) (i) 5.813 (ii) 6.037
 2. (b) (i) $g^{-1}(x) = 2\sqrt[3]{x-1}$ (ii) Domain = $\{x: x \in \mathbb{R}\}$, Range = $\{y: y \in \mathbb{R}\}$ (c)

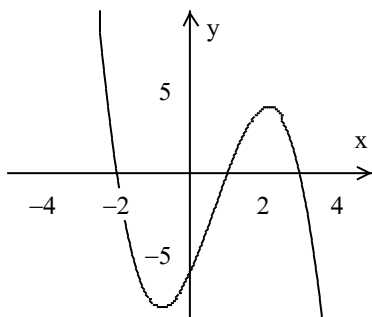

3. (a) $A_1 = -3$, (b) $\frac{2}{9}$ (c) $x = -2$ or $x = 1$
 4. (a) $3t - \frac{3}{4}t^2$ (b) $\sin^{-1}(x) + \frac{x}{\sqrt{1-x^2}}$ (c) The minimum point $(-2, -48)$
 5. (a) 0.8345 (b) $2^{x+1} \log_2 e + A$ (c) 2.1776
 6. (a) (i) 1 (ii) $\frac{83}{70}$ (iii) Var. = 5.71, Stdev. = 2.39
 7. (a) 36 (b) (i) $x = 0.3$
 (ii) 0.74 (iii) 0.6
 (c) 2300 ways
 8. (a) $\frac{4\sqrt{3}+3}{3}$
 (c) $78.5^\circ, 131.8^\circ, 228.2^\circ, 281.5^\circ$
 9. (a) (i) 1638 (ii) 73 (iii) 26.7%

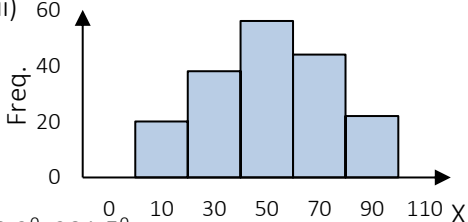

(b) (i) $f \circ g(x) = \log_4 \left(\log_2 \left(\frac{x+3}{2} \right) \right)$ (ii) $g^{-1} \circ f^{-1}(x) = 4(2^{2x}) - 3$

(iii) $x = 4$

10. (a) Constraints, $\begin{cases} x + y \geq 30 \\ x + 2y \geq 40 \\ x \geq 0, y \geq 0 \end{cases}$ objective function, $f(x, y) = 20x + 24y$

(b) 20 bed sheets and 10 box springs

(c) The minimum cost is Tshs. 640/-

EXAMINATION FIFTEEN

1. (a) Mean = 337.11, Std. dev = 29.36 (b) 0.691966

2. (a) $a = 5$ and $b = 6.5$, $f \circ f(x) = \frac{189x + 130}{20 + 26x}$ (b)

3. (a) $x = 2$ and $y = 1$ or $x = -\frac{73}{12}$ and $y = \frac{727}{48}$

(b) 38 (c) (i) $q = \frac{1}{3} \sqrt[3]{p} \times \sqrt{r}$ (ii) $144r - p^3 = 0$

4. (a) $\frac{d^2y}{dx^2} = \frac{12 - 18t - 6t^2}{(3t^2 - 4t)^3}$ (c) 1.25 m by 2.5 m

5. (a) $2x^4 + 6x^2 - \frac{1}{2x^2} + 6 \ln x + A$ (b) (i) $x = 3$ (ii) $y = 2x^2 - 12x + 34$

(c) 14 sq. units.

6. (a) $a = 6$ and $b = 4$ (b) (i) $Q_1 = 5$ (ii) 19 (iii) 16 (iv) 19.6

7. (a) 60 (b) (i) $\frac{1}{24}$ (ii) $\frac{1}{8}$ (iii) $\frac{1}{6}$ (iv) 0 (v) $\frac{1}{6}$ (vi) $\frac{1}{12}$ (c) 136 ways

8. (b) $\frac{\pi}{2}, \frac{2\pi}{3}, \frac{3\pi}{2}, \frac{4\pi}{3}$ (c)

9. (a) $a = \frac{1}{2}, b = 2$

(b) 30.9 yrs.

10. (a) $x = 3, y = -4, z = 1$

(c) $\begin{pmatrix} -3 & -8 \\ -2 & -5 \end{pmatrix}$

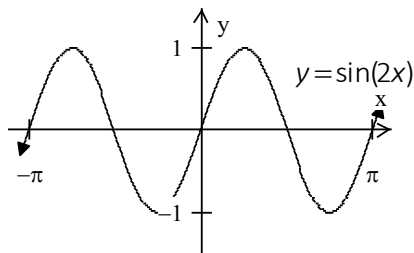
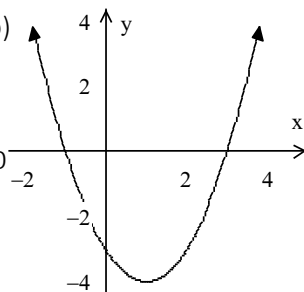

EXAMINATION SIXTEEN

1. (a) (i) 3520 yards (ii) 22.2m/s
 (b) (i) 1.321×10^{-15} (ii) 2.998×10^8 (iii) 1.097×10^{17} (iv) 1.411×10^{-26}
 (c) [mode] → [mode] → [mode] → [1] → [→] → [2] → [a?] → [=] → [b?] → [=] → [c?] → [=], $x_1 = k, x_2 = p$.

2. (a)

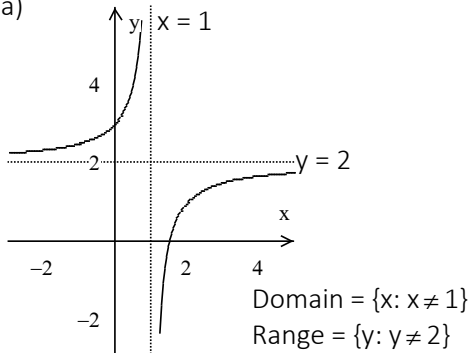

(b) Quotient: $2x^2 + 11x + 30$, Remainder: 100

(c) (i) 60.25 (ii) -52.25

3. (a) $x = 20, x = -4$ (b) $x = 6, x = -1$

4. (b) $\frac{2(x^2 - 5)^2(2x^2 + 6x + 5)}{(x + 2)^3}$ (c)

(i) 37.5m (ii) Graph

5. (a) $\frac{3}{4} + \frac{\sqrt{3}}{8}$

(b) $\frac{\sqrt{3}\pi}{3 + 2\sqrt{3}}$

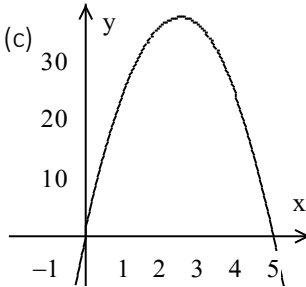

6. (a) 29.3 (b) 30.3 (c) 29.8 (d) an ogive

7. (a) (i) 0.15 (ii) 0.19 (iii) 0.64

(b) 360

8. (c) $a = 3.07$, Area = 4.3 cm^2

9. (a) 17.9

(b) Graph

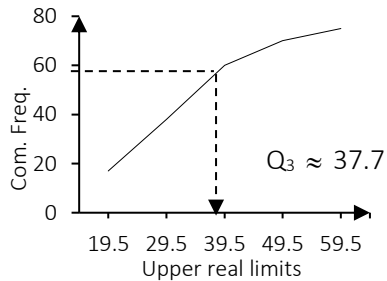
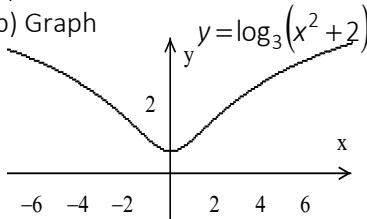

Domain = $\{x: x \text{ is a set of all real numbers}\}$

Range = $\{y: y \geq 0.63\}$

10. Constraints:
$$\begin{cases} 3x + 4y \geq 8 \\ 5x + 2y \geq 11 \\ x \geq 0, y \geq 0 \end{cases}$$
 Objective function, $f(x,y) = 60x + 80y$

The homemaker needs 2 kg of F1 and 500 gm of F2 to minimize the cost.
The minimum cost is Tshs 160/-

EXAMINATION SEVENTEEN

1. (a) 0.319 (b) 1.90×10^{13} (c) 0.908
2. (a) (i) $a = 2, b = 1$ and $d = 3$ (ii) $y = 2$ (b) ± 4
3. (a) $x = \frac{1}{2}, x = 1, x = 2$. (c) $A = \frac{5}{7}, B = \frac{2}{7}$
4. (a) $-\frac{\sin x}{\sqrt{\frac{1+\cos x}{1-\cos x}}(1-\cos x)^2}$ (c) 0.016m/s
5. (a) $\frac{9}{800}$ (b) $v = \left(-\frac{1}{t+3} + 1\right)$ m/s, $s = -\ln(t+3) + t - 2 + \ln 5$
6. (a) (i) mean = 49.85 (ii) 0.5275 (iii) $y = 91.85$ (iv) $k = 24.94$

(b) (i) Frequency distribution table

Data	10 – 16	17 – 23	24 – 30	31 – 37	38 – 44	45 – 51
Freq.	10	8	13	12	6	5

- (ii) 28.35 (iii) 43.04
7. (a) (i) 31,104 numbers (ii) 480 numbers.
(b) $P(A) = 0.064$ (c) 2160
 8. (a) $\frac{x-y}{\sqrt{4-(x-y)^2}} = \frac{x+y}{2}$ (b) (i) 62.58 cm^2 (ii) 14.03 cm

9. (a) 7.5 years

10. 8kg of mix A, 3 kg of mix B; C = Kshs 280 per day

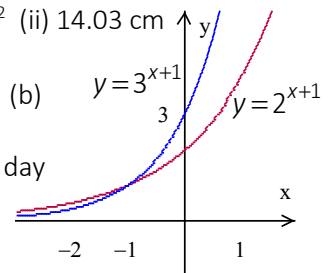

EXAMINATION EIGHTEEN

1. (a) 0.623 (b) 3.67 (c) 299.588

2. (a) (i)

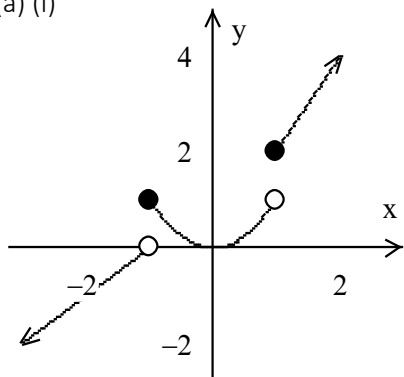

(ii) It is not a one to one function

(b) Domain = $\{x: x > 4 \text{ and } x \leq -0.5\}$, Range = $\{y: y \neq \pm\sqrt{2}\}$

3. (a) 784.7205 (b) 20 pencils (c) (i) 7304.6 newtons

(ii) 27.75m/s

4. (a) $\frac{dy}{dx} = -\frac{2x}{\sqrt{(1-x^2)(x^2+1)^3}}$ (b) $\frac{dy}{dx} = \sqrt{x} \left(\frac{5x^{7/2}}{x^5+2} - \frac{1}{2x^{3/2}} \right)$

(c) The maximum capacity is 9259.26 cm³.

5. (a) $2 \tan^{-1} \sqrt{x} + A$ (b) 343.67 (c) 20.94 sq. units

6. (a) Frequency distribution table

Data	Frequency
0 – 9	1
10 – 19	4
20 – 29	10
30 – 39	13
40 – 49	12
50 – 59	7
60 – 69	3

(b) 9.17

(c) 196.16

(d) 14

7. (a) (i) $\frac{1}{25}$ (ii) $\frac{6}{25}$ (b) $n = 4$

8. (c) Height of the building is $\frac{15+13\sqrt{3}}{2} \approx 18.8$ m

A person is $\frac{13}{2}(\sqrt{3}+1) \approx 17.8$ m away from the building.

9. (a) 2 years old

(b)

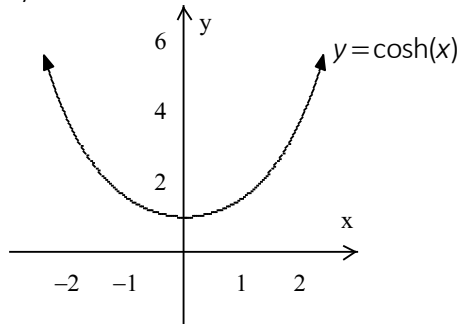

	Originality	Problemsolving	presenters	
10. (a) (i) Points:	St.Jude	16.5	18	17.5
	Makumira	12.5	14.0	17.0
	St.Joseph	16.0	19	18

	St.Jude	Makumira	St.Joseph	
Difficulty:	Originality	2	3	2
	Prob.solving	3	3	1
	Presenters	2	2	1

Total score for each contestant

	Originality	Problemsolving	presenters	
(ii)	St.Jude	122	138.5	68.5
	Makumira	101	113.5	56
	St.Joseph	125	141	69

(b) $a = -12$

EXAMINATION NINETEEN

1. (a) 19619.42 (b) $C = \begin{pmatrix} \frac{1}{4} & \frac{7}{4} & 0 \\ \frac{37}{48} & -\frac{51}{48} & \frac{11}{12} \\ \frac{25}{48} & -\frac{47}{48} & \frac{11}{12} \end{pmatrix}$ (c) 1.406

2. (a) (i) Not a function. Reason: One value of domain has two different values of range.

(ii)

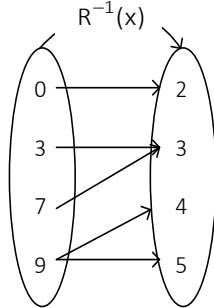

(b) $g(x) = x^2 + 1$

(c)

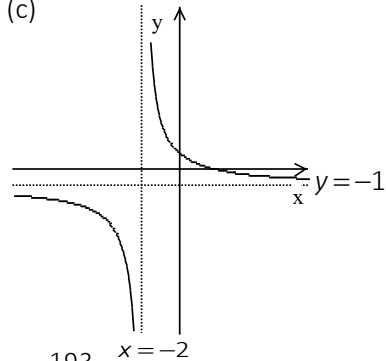

3. (a) 10.129

(b)
$$\sum_{n=1}^n \left(\frac{4n-3}{(2n+5) \times 2^{n+2}} \right)$$

(c) $\frac{193}{330}$

4. (a) $\frac{dy}{dx} = \frac{\cos x}{2\sqrt{\sin x}}$ (c) (ii) $\frac{dx}{dt} = 0.0037 \text{ cm/s}$ (iii) $\frac{dA}{dt} = 0.088$

5. (a) $a = 3$ (b) $\frac{2}{3}x^{3/2} + 2\sqrt{x} + 3x + A$ (c) $\frac{10}{3}\pi$

6. (a) 0.1962 (b) 0.4429 (c) $Q_1 = 8.1$ (d) 7.106 (e) 8.775

7. (a) 1000 (b) (i) 0.054 (ii) 0.49 (iii) 0.236 (iv) 0.764

8. (b) 33.18 (c) $x = 201.47^\circ, 338.53^\circ$.

9. (a) (i) $P = 13.54$ (ii) $t = 2.8$ (b) $x > 6.15$ (c) Domain = $\{x: x > -4\}$

10. (a) $A = \begin{pmatrix} \frac{12}{7} & \frac{3}{7} \\ \frac{15}{7} & \frac{8}{7} \end{pmatrix}, B = \begin{pmatrix} -\frac{10}{7} & \frac{1}{7} \\ -\frac{12}{7} & \frac{5}{7} \end{pmatrix}$

EXAMINATION TWENTY

1. (a) -0.6576 (b) 67.1087 (c) -4.1448

2. (a) (i)

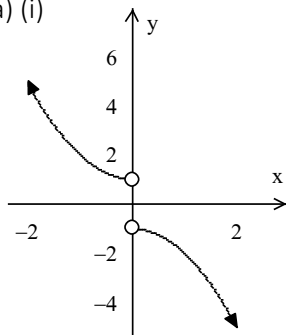

- (ii) Domain = $\{x: x \neq 0\}$

Range = $\{y: -1 < y < 1\}$

(b) $g \circ f(x) = x^2 - x$

3. (a) $\frac{8}{1} + \frac{17}{2} + \frac{32}{3} + \frac{57}{4} + \frac{100}{5}$ (b) The numbers: 12, 24, 30

(c) $(7p-2q)(7p-2q)$ (d) $\frac{a}{b} = -\frac{28}{47}$

4. (a) $\frac{dy}{dx} = -\frac{1}{2x\sqrt{x}} + \frac{1}{2\sqrt{x}}$ (b) $a=1, b=-2$ and $c=3$

(c) width = length = 5 cm

5. (a) $a=2$ (b) π^2 cubic units (c) 6 square units

6. Frequency distribution table

Class intervals	Frequency	Class mark	D	FD	U
5.5 – 14.5	10	10	-30	-300	-3
15.5 – 24.5	18	20	-20	-360	-2
25.5 – 34.5	24	30	-10	-240	-1
35.5 – 44.5	16	40	0	0	0
45.5 – 54.5	12	50	10	120	1

(i) Median = 30 (ii) Mean = 30.25 (iii) Standard deviation = 1.235

7. (a) $P(A \text{ or } B) = 0.75$ (b) 40320 words (c) (i) $\frac{1}{9}$ (ii) $\frac{2}{9}$ (iii) $\frac{4}{9}$

8. (b) $\tan^{-1}\left(\frac{2x}{1-x^2}\right)$ (c) $0^\circ, \pm 180^\circ, \pm 360^\circ$ (d) (ii) 6.7 cm

9. (a)

$x = 0.31$ and $x = 4$

Area = 10.51 square units

(b) rs. 2205.90/-, B invested Tshs. 4411.80 and C invested Tshs. 1102.90

(ii) Amount of A is Tshs. 2966.70/-

(iii) Interest of C is Tshs. 1184.10

10. To maximize the profit, 750 type A, 1625 type B should be sold

BAM

EXAMINATION TWENTY-ONE

1. (a) (i) 21.279 (ii) 0.8464 (b) 0.991 (c) (i) 28.45 (ii) 2.8631 (iii) 8.1973.

2. (a) (i) $f \circ g(x) = \sqrt{3x^2 - 2}$ (ii) $g \circ f(x) = 3x - 2$ (iii) $x = 1$

(b) Graph

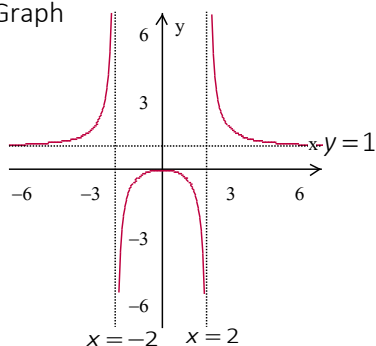

(c) $f(x) = x^2 + 2x + 5$

3. (a) (i) $1 + 3 + 3^2 + 3^3 + 3^4 + 3^5 + 3^6$ (ii) $2 + \frac{3}{2} + \frac{4}{3} + \frac{5}{4} + \frac{6}{5}$

(b) The common difference, $d = 8$

(c) (i) $25x - y^2 = 0$ and $y = \frac{5}{2\sqrt{6}}$

4. (a) $\frac{dy}{dx} = 2$ (b) $y = 2x$ (c) Point of inflexion at $(-1, 1)$ (d) $x = 3$

5. (a) $\frac{2}{3}x(x-1)\sqrt{x^2-x} + A$ (c) 7.7 sq. units (d) 117π

6. (a) (i) $Q_1 = 28$ (ii) $Q_3 = 43$ (iii) $P_{50} = 36$ (iv) $P_{60} = 10.2$
 (b) Variance = 20.6875, Standard deviation = 4.548

7. (a) $x = 2$ or $x = -3$ (b) 4368 ways

8. (c) $0^\circ, 60^\circ, 180^\circ, 300^\circ, \pi$

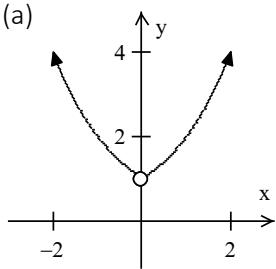
9. (a)  (b) $\frac{d^2y}{dx^2} = 4y$

(c) $x = 10, y = 1$ or $x = 1, y = 10$

10. (a) $a = 2, b = 5$ and $c = -3$ (b) $x = 2, y = 1$ and $z = -2$
 (c) $x = 1, y = 0$ and $z = 1$

EXAMINATION TWENTY-TWO

1. (a) -0.5 (b) 3.072 (c) $x = -7.04$ (d) 51

2. (a) The quotient is $3x^2 - 8x + 26$

(b)

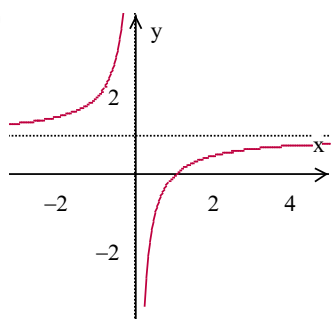

(c)

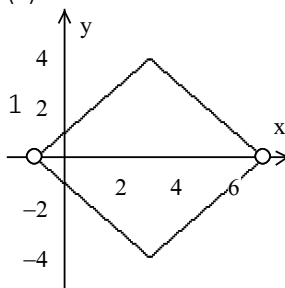

3. (a) The difference, $d = 3.8$ (b) $x = \pm 2.1$, $y = 3$ or $x = 4.24$ or $y = 1.48$

(c) The numbers are, 5.2, 7.4, 9.6, 11.8

4. (a) $\frac{dy}{dx} = \frac{1}{x\sqrt{x^2-1}}$ (b) $4\sec(2x)(2\tan^2(2x)+1)$

5. (a) $-\frac{1}{3}\log_e(2-3x)+A$ (b) 4.5 sq. units (c) 149.3 cubic units

6. (a) $X = 5$ (b) Mean 25.34, Standard deviation = 0.97

7. (a) (b) 531,441 ways (c) (i) 8008 (ii) 3136 (iii) 3003 (iv) 2436

(d) (i) 10,000 ways (ii) 5040 ways (iii) 0.504

8. (a) $\sec^2 A \tan^2 A$ (b) $-336/527$ (c) $\tan 75^\circ = \frac{3+\sqrt{3}}{3-\sqrt{3}}$ (d) $(x+1)y^2 = 2$

9. (a) 37636 people (b) 7 years

10. (a)

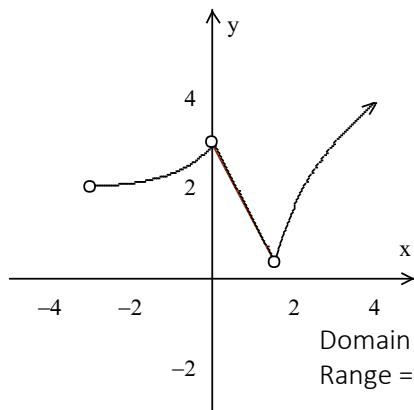

Domain = $\{x: x > -3, \text{ except } 0, 1.5\}$

Range = $\{y: y > 0.375\}$

(b) He should produce 3 packages of each type

EXAMINATION TWENTY - THREE

1. (a) 1.38659 (b) (i) -101 (ii) $\begin{pmatrix} 8 & 2 & 7 \\ 7 & 0 & 8 \\ 1 & 5 & 3 \end{pmatrix}$ (c) (i) 62.41 (ii) 19.66

2. (a)

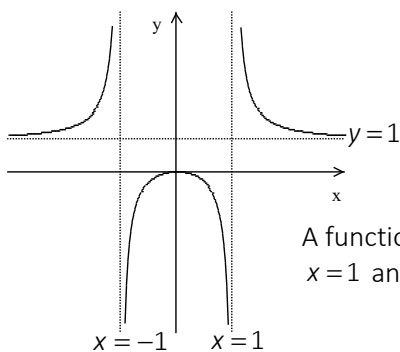

A function is defined when $x = -1$,
 $x = 1$ and $y = 1$

- (b) (i)

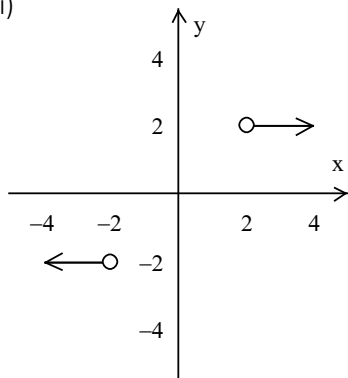

(ii) Domain = $\{x : x > 2 \text{ and } < -2\}$

Range = $\{y : y = -2, 2\}$

3. (a) $x = 1$ and $y = 4$ (b) 21, 34 and 55. (c) (i) $r = 2$, (ii) $d = 2.5$ and (iii) $G_1 = 5$
4. (a) $\frac{dy}{dx} = 4x + 3$ (b) $\frac{dy}{dx} = \frac{4}{3t}$ (c) 0.031 cm/s
5. (a) $\frac{1}{2}(\sqrt{x} + 3)^4 - 8(\sqrt{x} + 3)^3 + 54(\sqrt{x} + 3)^2 - 216(\sqrt{x} + 3) + 162 \ln(\sqrt{x} + 3) + A$
(b) Area = $\frac{4}{3}$ square units (c) 0.7854
6. (a) (i) Mean = 53.2, (ii) $Q_1 = 36$, $Q_2 = 59$, $Q_3 = 73$ (iii) $P_{60} = 68$ (iv) $P_{75} = 73$
(b) (i) Variance = 35.45

(ii) An ogive

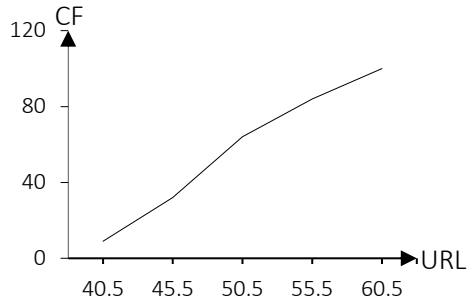

(iii) Histogram

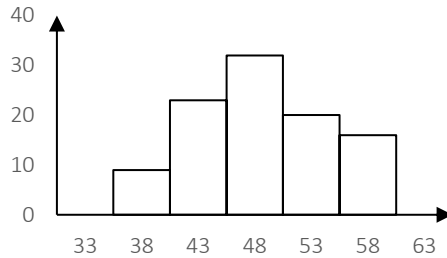

7. (a) (i) 0.23 (ii) 0.45 (iii) 0.89 (b) 0.75 (c) 0.31
 8. (b) (i) $\alpha = 53.13^\circ$ (ii) $83.13^\circ, 203.13^\circ, 263.13^\circ$
 9. (b) $r = 11.3\%$
 10. (a) $x = 30, y = 24$ (b) $x = 7$

EXAMINATION TWENTY - FOUR

1. (a) 4.17 (b) 1,099,455,338 (c) (i) 759 (ii) 60379

2. (a) $f(x) = 2x + \ln x - \frac{1}{2}$ (b) $x^2 - 4x + 8$ remainder is -21

(c) Domain = $\{x: x \neq -2\}$
 Range = $\{y: y < 0\}$

3. (a) (i) 2001: 1,120,000 papers
 2002: 1,792,000 papers
 (ii) 2000 - 2009: 76,965,814 papers
 (b) $x = 2.5, y = 4.5$
 (c) $x = 3.586$

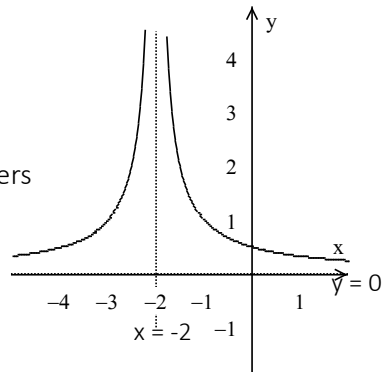

4. (a) $\frac{dy}{dx} = -\frac{3}{(x-1)^2} \sec^2\left(\frac{x+2}{x-1}\right)$

- (b) $\frac{d^3y}{dx^3} = -4 \sin(2x)$

$$(c) \frac{dy}{dg} = \frac{1}{3} e^{-3x} \left(\cos x - \frac{1}{2x^2} \sin \left(\frac{1}{2x^2} \right) \right)$$

$$(d) (i) \frac{dr}{dt} = -0.32 \text{ cm/s} \quad (ii) \frac{dh}{dt} = -0.22 \text{ cm/s}$$

$$5. (a) (i) \frac{1}{2} \ln |\sec 2x + \tan 2x| + A \quad (ii) 3 + 2 \ln \left(\frac{2}{5} \right) \quad (b) 7.35 \text{ sq units}$$

$$(c) 107.23 \text{ square units}$$

$$6. (a) (i) \text{Med} = 18.23 \quad (ii) \text{Var} = 48.69 \quad (iii) P_{65} = 21.06 \quad (b) (i) 13.5 \quad (ii) 73.8$$

$$7. (a) 0.7 \quad (b) (i) \frac{1}{56} \quad (ii) \frac{5}{14} \quad (iii) \frac{19}{42} \quad (c) P(B|S) = \frac{8}{15}$$

$$8. (a) 38.03 \text{ cm}^2$$

$$9. (a) x = -0.76 \quad (b) 28.27\% \quad (c) (i) \text{Tshs } 52308.80/- \quad (ii) \text{Tshs } 178949.50/- \quad (iii) \text{Tshs } 126,640.70/-$$

$$10. (a)$$

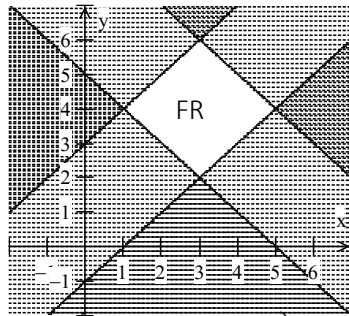

The maximum is 39 at (3, 6)

$$(b) (i) \text{Adj}(A) = \begin{pmatrix} 2 & -9 & -1 \\ -29 & 27 & -20 \\ 14 & 6 & -7 \end{pmatrix}$$

$$(ii) A^{-1} = -\frac{1}{69} \begin{pmatrix} 2 & -29 & 14 \\ -9 & 27 & 6 \\ -1 & -20 & -7 \end{pmatrix}$$

$$(c) x = 30, y = 60 \text{ and } z = 28$$

EXAMINATION TWENTY - FIVE

$$1. (a) 3.99321 \quad (b) (i) 48 \quad (ii) 16.7 \quad (iii) 280 \quad (iv) 684380$$

$$2. (a) (i)$$

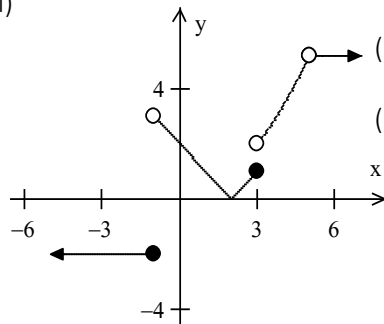

$$(ii) \text{Domain} = \{x: \text{all real numbers}\}$$

$$\text{Range} = \{y: y = -2, 0 \leq y < 5.2\}$$

$$(iii) 25.6$$

- (b) (i) $f(x) = \frac{5}{6}x^2 + \frac{5}{6}x + 3$ (ii) Turning point $\left(-\frac{1}{2}, 2\frac{19}{24}\right)$
- (c) $(f \circ g) \circ h(x) = f \circ (g \circ h(x)) = 2a - a\sqrt{x+2} + b$
3. (a) Kshs. 750/- (b) (i) Let y be adults: $x = \frac{905-5y}{2.5}$ (i) $x = 38$
 (c) (i) Kshs. 6300/- (ii) Kshs. 1357.7/-
4. (a) $f'(x) = -\frac{1}{(x+1)^2}$ (b) $\frac{dA}{dt} = -8\pi$ (c) $\frac{dy}{dx} = \frac{x^6 - 16x^3}{(x^3 - 4)^2}$ (d) 3.0155
5. (a) $2 \tan^{-1}(\sqrt{x}) + A$ (b) 199.48 sq. units (c) 10.86 cubic units
6. (a) (i) 4.5 (ii) 5 (iii) 4.88 (b) (i) 41.79 (ii) 60 (iii) 449.01
7. (a) 10626 (b) (i) 1440 (ii) 3600 (c) 720 ways
8. (b) $296.55^\circ, 115.55^\circ$ (c) 3.475cm (c) $R = \pm 13, B = 67.38^\circ$
9. (a) 8.95% (b) 5 years
10. (a) 6 circuits of type A and 3 of type B (b) Maximum profit is Tshs 66/-

EXAMINATION TWENTY - SIX

1. (a) 1.480228439 (b) (i) 32.1 (ii) 11.16 (iii) 124.59 (iv) 224580 (c) -3.92
2. (a) (i)

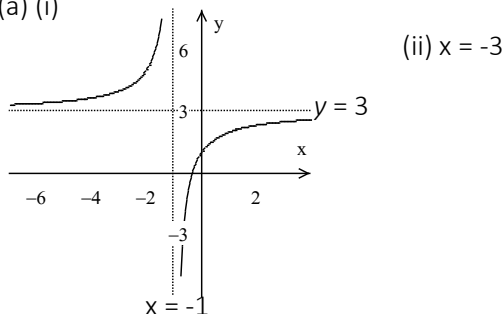

- (b) Domain = $\{x: x > 4\}$ and Range = $\{y: y \neq 0\}$
- (c) (i) $\frac{1}{2}x^2 + \frac{5}{4}x - \frac{21}{8}$ the remainder is 3.625
 (ii) $3x^2 + 27x + 150$ the remainder is 301
3. (a) (i) $20 + 16 + \frac{64}{5} + \dots$ (ii) $\frac{4}{5}$ (iii) 50 (b) 40 and 48 (c) 9.3 years
4. (a) $-23/13$ (b) Max (-2, 15) and Min (1, -12) (c) 2
- (d) $\frac{3}{(x-2)^2} \sin\left(\frac{x+1}{x-2}\right) \cos\left(\cos \frac{x+1}{x-2}\right) \sin\left(\frac{x+1}{x-2}\right)$

5. (b) $-\ln(1 + \cos x) + A$ (c) 109.87 sq. units
 6. (a) A frequency distribution table

Class intervals	Frequency
3 – 3¾	4
4 – 4¾	5
5 – 5¾	6
6 – 6¾	7
7 – 7¾	10
8 – 8¾	4

(b) 2.37

(c) Histogram

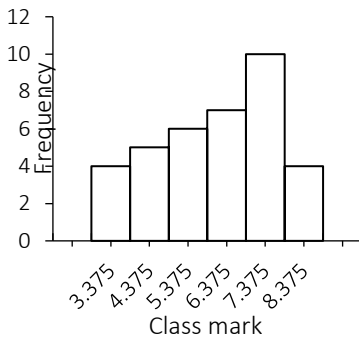

(d) An ogive

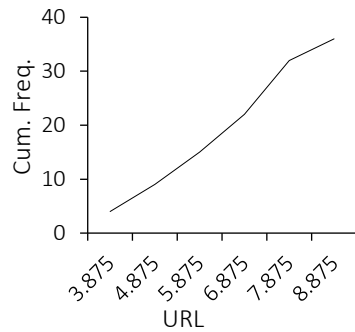

7. (a) (ii) $\frac{3}{16}$ (iii) $\frac{5}{16}$ (b) 180 (c) 210

8. (a) $\frac{1}{a} \cot \theta$ (d) $\frac{1 - \sqrt{3}}{1 + \sqrt{3}}$

9. (a)

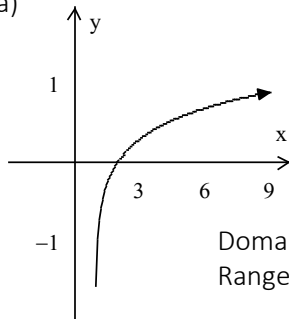

Domain = $\{x : x > 0\}$
 Range = $\{y : y \text{ is all real numbers}\}$

- (b) (i) $A(t) = A_0 e^{0.000121t}$ years (ii) 8.898%

10. (b) $x = 2, y = 3$ and $z = 5$ (c) $X = \begin{pmatrix} 1 & 2 \\ 3 & -4 \end{pmatrix}$ and $Y = \begin{pmatrix} 0 & 7 \\ 2 & 3 \end{pmatrix}$

EXAMINATION TWENTY-SEVEN

1. (a) 16.26 (b) -1331 (c) Mean = 11.432, std. dev. = 19.144
 2. (b) (i) $a = -\frac{1}{6}$ when $b = -13$ or $a = -\frac{2}{3}$ when $b = 5$ (ii) $x = 12$ or $x = 3$

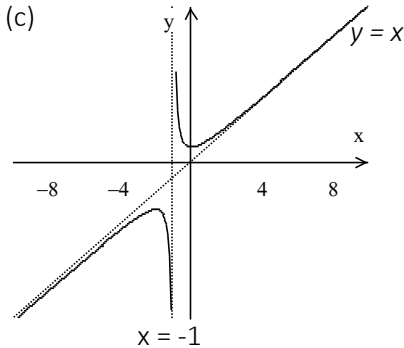

3. (a) 22356 (b) 18 or 81 (c) 97.2
 4. (a) $a = -5$ (b) $\frac{d^2y}{dx^2} = \frac{12x^2 + 4x^2\sqrt{x} - 21x\sqrt{x} - 7x}{4x^2\sqrt{x}(\sqrt{x}+1)^3}$ (c) $8\sqrt{8}$ cubic units

5. (a) $f(x) = -\frac{1}{15(5x-3)^3} + \frac{1}{405}$ (b) (i) $6x - 3\sin(2x) + A$
 (ii) $\frac{1}{2}(x+1)^2 \ln(x+1) - \frac{1}{4}x^2 - \frac{1}{2}x - \frac{1}{4} + A$

(c) $\frac{4}{\sqrt{3}} - \frac{2}{3}\pi$

6. (a) Mean = 38.06, std. dev. = 6.24
 (b) (i) Frequency distribution

Intervals	60 – 69	70 – 79	80 – 89	90 – 99
Frequency	8	18	12	2

(ii) 76.5 (iii) 8.124

7. (a) 715 (b) (i) 1440 (ii) 3600 (c) (i) 0.54 (ii) 0.32
 8. (a) $-2 - \sqrt{3}$ (b) 11.14 cm (d) $26.15^\circ, 93.85^\circ$
 9. (a) $x = 2.54$ (b) $P = 22.2$ (c) 33 years

10. (a)
$$\begin{cases} 2x + 3y \leq 28 \\ 4x + y \leq 36 \\ 3x + 5y \geq 21 \\ 5y - 4x \leq 10 \end{cases}$$

(c) 8 tecno and 4 Samsung phones (d) Max. is USD 19.2/-

EXAMINATION TWENTY-EIGHT

1. (a) 13.725244 (b) 1.589 (c) Mean = 46.125, Variance = 502.48

2. (a)

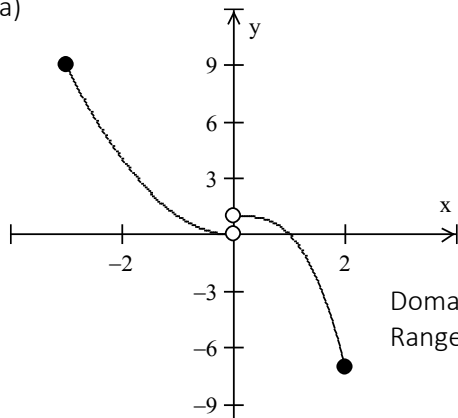

Domain = $\{x: -3 < x \leq 0 \text{ and } 0 < x \leq 2\}$
 Range = $\{y: -7 \leq y \leq 9\}$

$$(b) (i) h \circ g(x) = \begin{cases} 9x^2 - 30x + 24 & \text{if } 1 < x \leq 5 \\ 11 - 6x & \text{if } \frac{1}{3} < x \leq 1 \end{cases} \quad (ii) 110$$

3. (a) 132, 182, 240 (b) (i) 375 (ii) 93750 (c) $x = 7.5, y = 2.25$ or $x = 6, y = 4.5$
 (d) -46.15%

4. (a) $\frac{dy}{dx} = \frac{2}{1 + 4x^2}$ (b) Max. (-0.5, 2) and Min. (0.5, 0) graph below

$$(c) \frac{dy}{dx} = \frac{6x + \cos(2y)}{2x \sin(2y) + 2y} \quad (d) (i) 6\% \quad (ii) 9\%$$

5. (b) $\frac{1}{8} \sin(4x) + \frac{1}{2}x + A$ (c) 1.348 cubic units

6. (b) 21.95 (c) $x = 11.1$ or 12.0

7. (a) (i) Not mutual exclusive events

(ii) Independent events

(iii) 0.3

(b) (i) 0.83 (ii) 0.00145

(c) (i) 1176 (ii) 1281 (iii) 2982

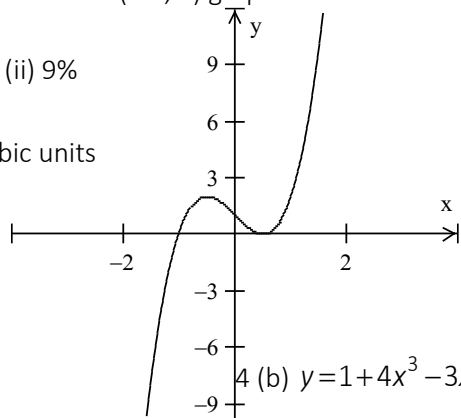

$$(b) y = 1 + 4x^3 - 3x$$

8. (a) $x^2y - y(1 - x^2) = 2x\sqrt{1 - x^2}$ (d) 30° and 210° (e) $y = \sin(2\theta)$

9. (a) (i) 30 gm (ii) 10.6 gm (iii) 1.875 gm (b) graph below (c) Tshs. 3222/-

10. (b) Graph below

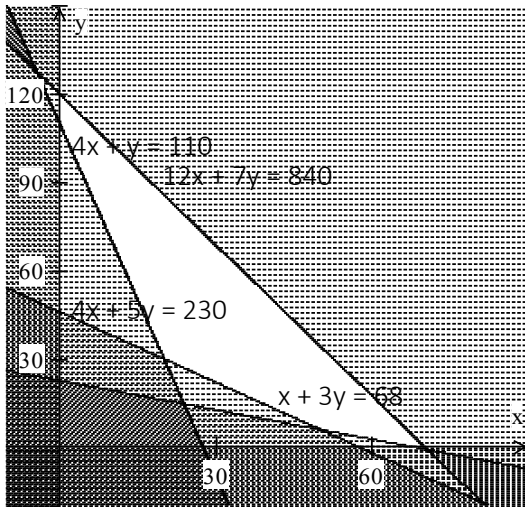
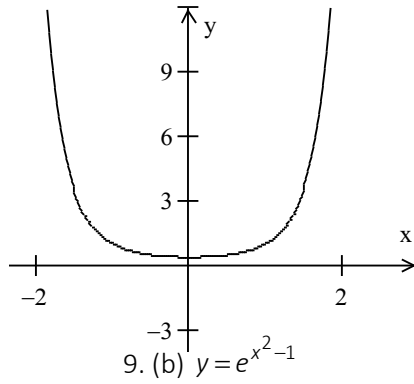

(ii) The maximum is 350 and minimum is 160

EXAMINATION TWENTY-NINE

1. (a) 1.025° (b) (i) 20.29 (ii) 23.86 (iii) 52273 (iv) 2435

2. (b) Graph below (c) $a = 5$ and $b = -2$

3. (a) 1.187

(b) 18 and 12

(c) $x^3(x^3 - a^2y)^{-1}$

(d) -4, -12, -36, -108

4. (a) $\frac{dy}{dx} = -\sin(x+1)$

(e) 4.8 ltr/min

(f) $\frac{dy}{dx} = \frac{2+2t^2}{(2t+t^2)(1-t)^2}$

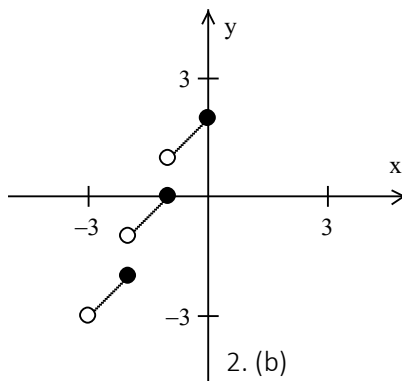

2. (b)

5. (a) $\ln \sqrt{\frac{x-1}{x+1}} + A$ (b) 1 cubic units (c) $\ln(5)$ square units

6. (a) (i) 13 (ii) $Q_1 = 12$, Med. = 13, $Q_3 = 17$ (iii) $18\frac{1}{3}$

(b) Freq. distribution table

Class intervals	Frequency
15 - 18	8
20 - 23	13
25 - 28	15
30 - 33	18
35 - 38	18
40 - 43	16
45 - 48	7
50 - 53	5

Mode = 29 or 34

Variance = 89.31

(c) $X = 26$

7. (a) $n = 7$ (b) (i) 0.491 (ii) 0.509 (iii) 0.134

8. (a) 115.9° or 244.1° (b) $x = 60^\circ$ and $y = 75^\circ$ or $x = 120^\circ$ and $y = 15^\circ$.

(c) Graph $y = \cos(2x) - 2\sin(x)$

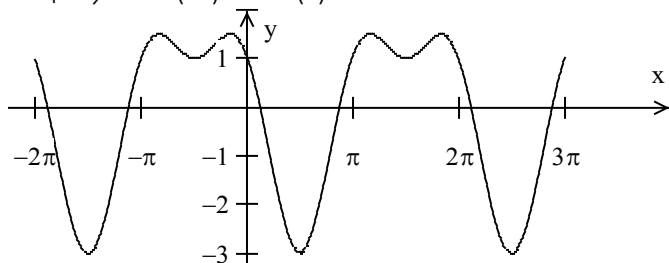

9. (a) 16 (b) $x = \frac{3}{e^2 + 2}$ (c) 234.3 hours

10. (a) $\begin{pmatrix} 33 & 36 \\ 13 & 17 \end{pmatrix}$ (b) $x = 6, y = 21$ and $z = 1$

EXAMINATION THIRTY

1. (a) -31483.84 (b) 0.17615525 (c) $x = 1.21$ or $x = -0.683$
 2. (a) (i) (ii) Range = $\{y: -4 \leq y \leq 1\}$

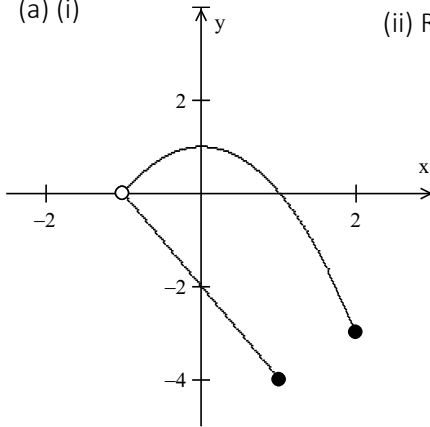

$$(iii) f \circ g(x) = \begin{cases} 3 - 2x & \text{if } 1 < x \leq 2 \\ 2x - x^2 & \text{if } 2 < x \leq 3 \end{cases}$$

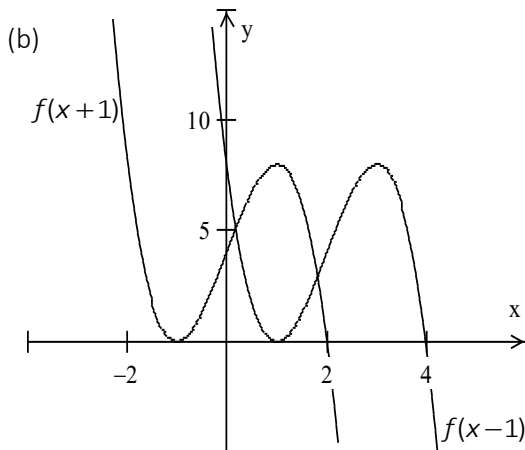

3. (a) (i) $A_{10} = 32x + 61y$ (ii) $x = 3$ and $y = 10$ (iii) 22750
 (b) Sarah Tshs 4000/- Baraka Tshs 6000/- Carlos Tshs 2000/-
 (c) $4/11$ (d) $S_n = \frac{8}{81}(10^{n+1} - 9n - 10)$, $S_8 = 98765424$

4. (a) $f'(x) = -\frac{2}{x^3}$ (b) $\frac{d^2y}{dx^2} + \frac{dy}{dx} - 2y = 0$ (c) Min (5.3, -75.8), Max (0, 0)
5. (a) $y = \frac{3}{2}x^2 - \frac{4}{x} + 3x + \frac{15}{2}$ (b) $6\ln(2) - 2$ (c) 3.351 cubic units (d) $A = \frac{1}{2}$ and $B = \frac{5}{2}$, $\frac{1}{2}\ln(x-3) + \frac{5}{2}\ln(x+1) + A$
6. (a) 11 (b) (i) 977 (ii) 38507 (c) (i) $x = 5$, $y = 8$ (ii) $Q_1 = 5$, $Q_2 = 5$, $Q_3 = 7$ (iii) 4.05
7. (a) (i) Gambling (ii) weather forecasting (iii) betting (iv) experimentation (v) Insurance (vi) politics (vii) lottery tickets (viii) quality test.
 (b) (i) 0.27 (ii) 0.17 (iii) 0.45 (c) 2,903,040
8. (b) $x = 120^\circ$, (c) Graph below

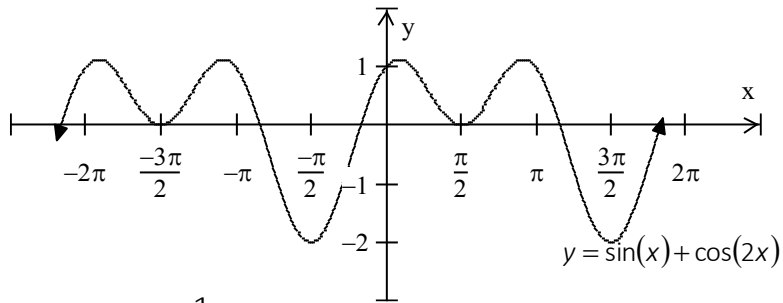

9. (a) $x = 3$ or $x = \frac{1}{\sqrt[4]{3}}$ (b) Tshs 2,820,000/-

10. (a) $X = \begin{pmatrix} -17 & -9\frac{b}{a} \\ -11\frac{a}{b} & 5 \end{pmatrix}$

(b) Constraints

$$x \geq 3, x \leq 12, y \geq 4, y \leq 15$$

$$x + y \leq 20, x \geq 0 \text{ and } y \geq 0$$

The objective function: $f(xy) = 10x + 25y$

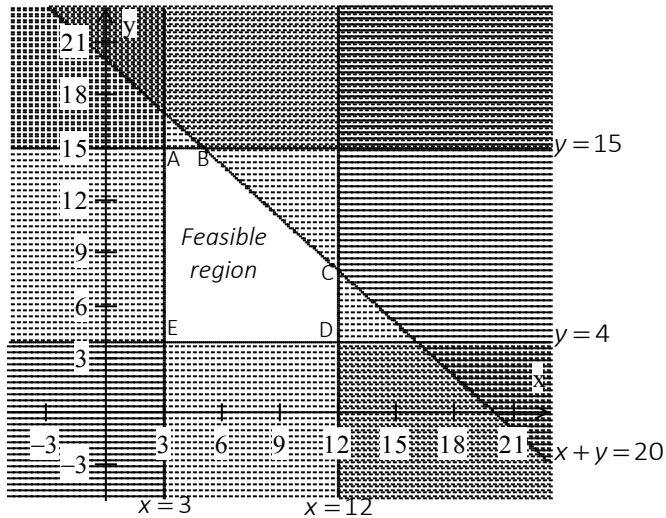

Table of results

Corner points	Objective function $f(xy) = 10x + 25y$
A(3, 15)	405
B(5, 15)	425
C(12, 8)	320
D(12, 4)	220
E(3, 4)	130

A student should answer 5 questions of type A and 15 questions of type B, the maximum score is 425



References

1. Crawshaw, Janet, and J. Chambers. *A Concise Course in Advanced Level Statistics: with Worked Examples*. Oxford University Press, 2014.
2. Backhouse, John K., et al. *Pure Mathematics 2*. Longmans, 1985.
3. Backhouse, J. K., et al. *Pure Mathematics*. Longman, 1995.

Complete revision for
**Secondary Basic Applied
Mathematics**

The complete revision for secondary basic Mathematics is a book for both teachers and students.

The writer intends to facilitate learning through solving of of questions.

The book also provides the useful trick for easy mastery of the concepts.

This book follows the new format of NECTA examinations.

Loibanguti, B.M

BSc. with Education - University of Dar Es Salaam, Tanzania
for more visit www.jihudumie.com